

# ADAPTOR PARTS KITS

All PVX Series Vane Pumps  
FOR TANDEM MOUNTING

“A” Design Series

Continental manufactures all P1 versions of the PVX pump with a through drive shaft that makes it easy to install another pump in tandem. When used as a single pump, the rear cover plate is bolted over the cavity in the body of the pump to seal the pump. To identify the P1 pumps, look for the easily recognizable rear cover plate. It has four (4) distinct bolts (see illustration to the left).

It is possible to mount any other type of flange mounted pump to P1 versions of the PVX pumps including other vane pumps, axial piston pumps, radial piston pumps or gear pumps provided the tandem pump has the same dimensions as the PVX pump shafts (refer to the PVX Pump product catalog). P1 versions are available in SAE version flanges. Adaptor kits are available to mount pumps with the same size mounting flange as the lead pump or smaller. Please insure the adaptor kit and tandem pump are compatible with the lead pump. The tandem pump must have the same direction of rotation as the lead pump. The chart below lists SAE versions of the PVX pump combinations and adaptor kits.

Use the chart below to determine the correct adaptor kit for any make or model flange mounted pump. Consult your Continental representative for assistance if necessary. For combinations with more than two (2) pumps, please consult the factory.

**When ordering, please include the pump model number and design letter series.**

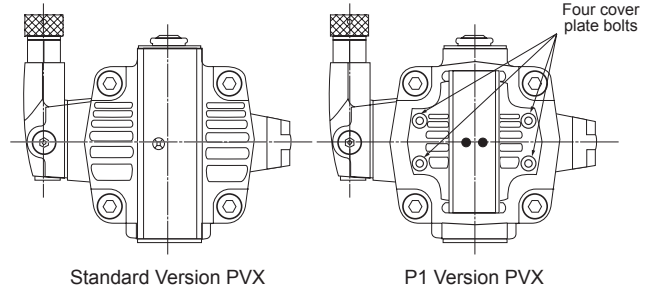

## ADAPTOR KITS

LEAD PUMP (SAE)	TANDEM PUMP MOUNTING	ADAPTOR KIT NUMBER
PVX-8	PVX-8 to S.A.E. “A” keyed	264240
PVX-11/15	PVX-8 to S.A.E. “A” keyed	264243
PVX-11/15	PVX-11/15 to S.A.E. “B” keyed	264244
PVX-11/15	PVX-11/15 to S.A.E. “B” splined	264242
PVX-20/29/36	PVX-8 to S.A.E. “A” keyed	264248
PVX-20/29/36	PVX-11/15 to S.A.E. “B” keyed	264249
PVX-20/29/36	PVX-11/15 to S.A.E. “B” splined	264247
PVX-20/29/36	PVX-20/29/36 to S.A.E. “C” keyed	264250
PVX-46/60/75	PVX-8 to S.A.E. “A” keyed	264257
PVX-46/60/75	PVX-11/15 to S.A.E. “B” keyed	264258
PVX-46/60/75	PVX-11/15 to S.A.E. “B” splined	264254
PVX-46/60/75	PVX-20/29/36 to S.A.E. “C” keyed	264259

# ADAPTOR KIT PARTS IDENTIFICATION

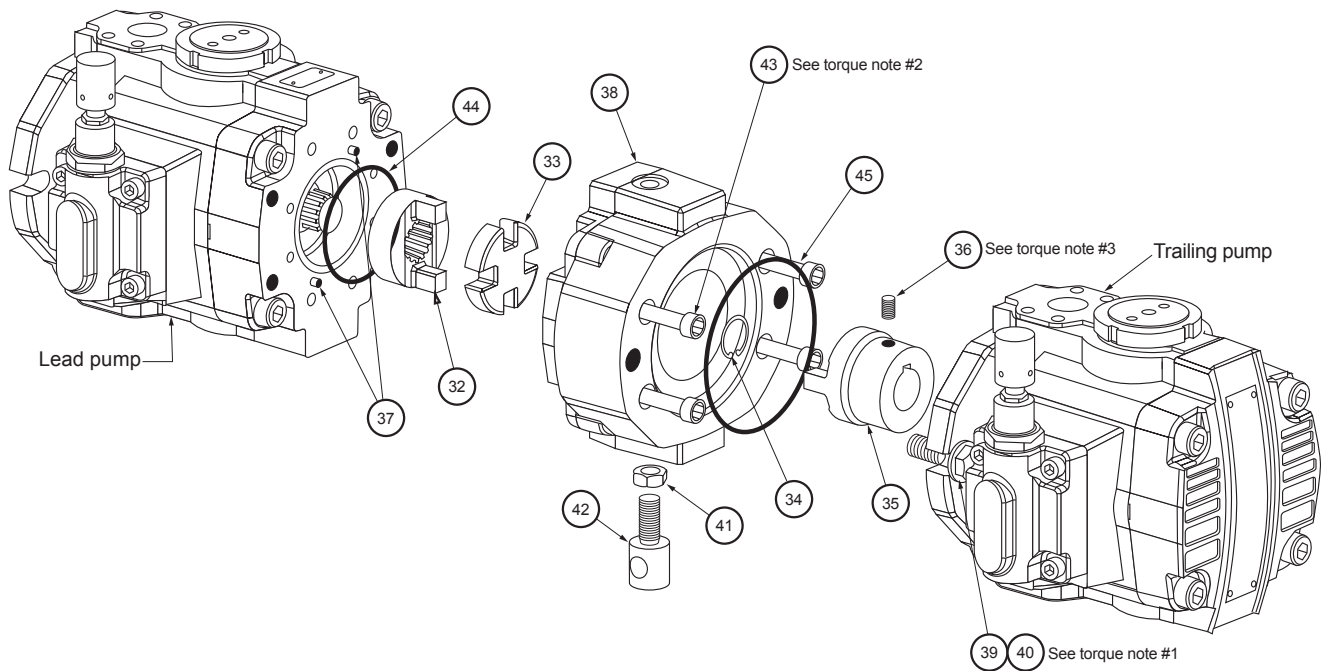

REF	DESCRIPTION
32	Coupling Half, Spline
33	Coupling Disc
34	Retaining Ring
35	Coupling Half, Combo
36	Set Screw
37	Roll Pin
38	Adapter
39	Washer
40	Hex Head Cap Screw
41	Jam Nut
42	Support
43	Soc. Head Cap Screw
44	O-Ring, ASA-043
45	O-Ring

<b>Torque Note #1</b>	
Torque to 780 lb/in (Torque to 88 Nm)	PVX-8
Torque to 1050 lb/in (Torque to 119 Nm)	PVX-11/15
Torque to 1800 lb/in (Torque to 204 Nm)	PVX-20/29/36
Torque to 2000 lb/in (Torque to 225 Nm)	PVX-46/60/75
<b>Torque Note #2</b>	
Torque to 400 lb/in (Torque to 46 Nm)	PVX-8
Torque to 550 lb/in (Torque to 62 Nm)	PVX-11/15
Torque to 850 lb/in (Torque to 96 Nm)	PVX-20/29/36
Torque to 2300 lb/in (Torque to 260 Nm)	PVX-46/60/75
<b>Torque Note #3</b>	
Torque to 280 lb/in (Torque to 31.5 Nm)	PVX-11/15
Torque to 330 lb/in (Torque to 37 Nm)	PVX-20/29/36

## INSTRUCTIONS FOR INSTALLING A TANDEM PUMP

1. Remove all plastic protective plugs from components before installation.
2. Prior to installation, Continental recommends pouring a small amount of clean hydraulic circuit fluid into the pump inlet ports and rotating the pump shafts by hand in the direction indicated by the arrow cast into the pump body (all Continental pumps rotate from the thrust block to compensator). This insures lubrication at initial start-up.
3. Remove the four (4) rear cover plate bolts and the rear cover plate from the lead pump exposing the through drive shaft. Hydraulic fluid may spill from the pump as the seal breaks from the pump body. This is normal.

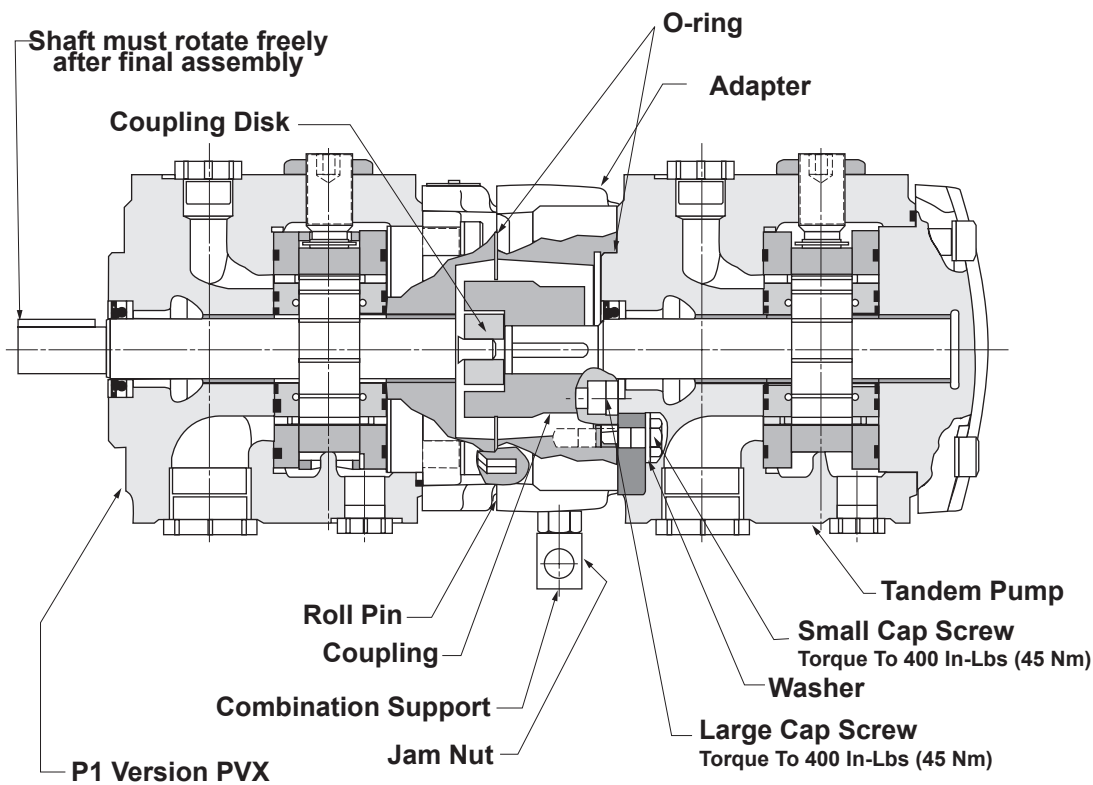
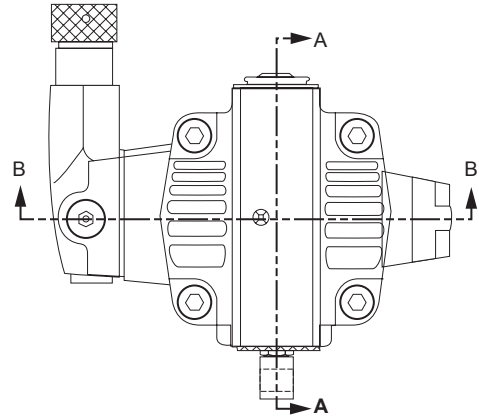

SECTION A – A

4. The illustration shows the adaptor kit and the combination assembly. Attach the adaptor kit and tandem pump as shown. Shaft alignment is maintained by two (2) roll pins between the adaptor kit/lead pump and the pilot on the mounting flange of the tandem pump. Two (2) steel coupling halves provide engagement. When the pumps are bolted together, the adaptor kit holds the coupling captive between the two shafts.

## INSTALLING A TANDEM PUMP (Continued...)

5. Turn the one exposed shaft in the direction of the arrow cast into the pump body. The shafts should rotate freely. If not, please consult your Continental representative.
6. If the P1 pump is not installed, install the combination unit in accordance with Continental PVX pumps installation instructions.

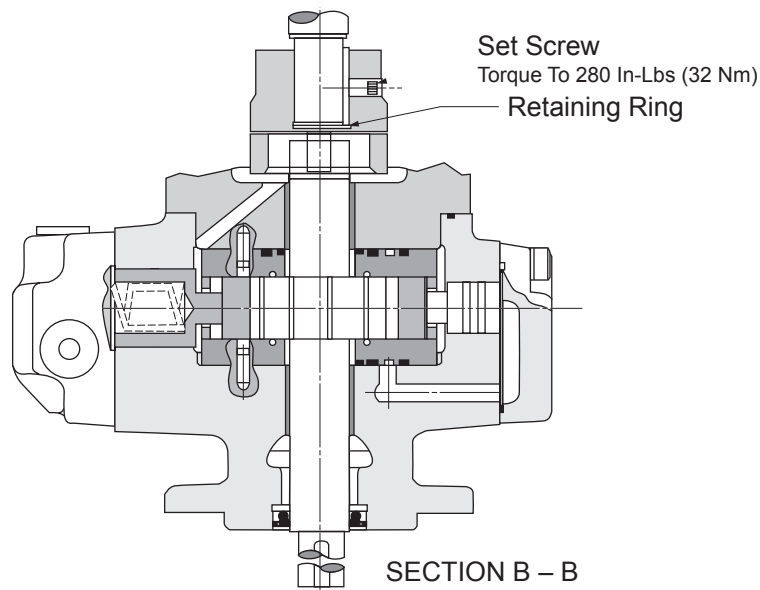

**NOTE:** The required input horsepower of the tandem pumps will be the summation of the required horsepower for each pump. For example, a PVX-11 pump requires input power of approximately 15 hp and a PVX-8 requires input power of approximately 11 hp. A tandem pump combination of PVX-11/PVX-8 would require input power of approximately 26 hp.



Continental Hydraulics  
4895 12th Avenue East  
Shakopee, MN 55379  
Phone: (952) 895-6400 Fax: (952) 895-6444  
[www.continentalhydraulics.com](http://www.continentalhydraulics.com)

Because Continental Hydraulics is continually improving its' products, specifications and appearance are subject to change without notice.

Form No. 264494 Rev. 07/08 © 2008, Continental Hydraulics. Printed in U.S.A