



SERVICE MANUAL

PVR50 Flanged Series Pump

Installation, Startup, Operating Instructions, Parts Pages, Repair Procedures

“L” Design Series



This service manual applies to products with Ordering Codes like the sample in Figure 2.

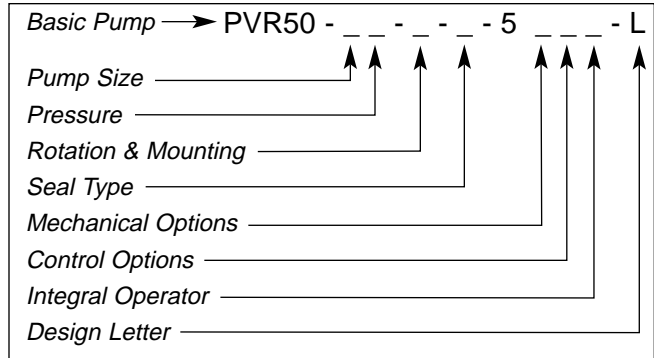

Figure 2



CAUTION - Before performing any service operation on any pump, be sure that all pressure has been relieved from BOTH SIDES of the system.



CAUTION - Before performing any service operation on any pump, disconnect or lock off power supply.



CAUTION - Before starting pump, be sure that any resulting machine function will not endanger persons or equipment.

PRODUCT IDENTIFICATION

Each pump has an Ordering Code stamped on its nameplate. See Figure 1 for the location of the Ordering Code.

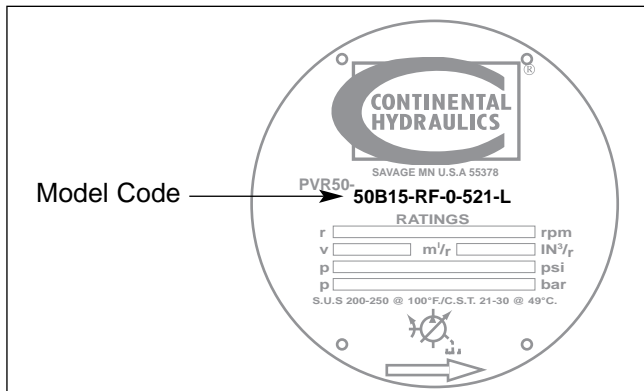

Figure 1

INSTALLATION

PUMP DRIVE AND MOUNTING

When mounting the pump and motor, care must be taken to align the pump and motor shafts within .003 T.I.R. Direct inline through a jaw type/flexible web coupling is recommended for all Continental pumps. Tire-type flexing elements and chain-type drives are not recommended. With belt drives, please consult factory.

To avoid axial and radial end loading of the pump shaft, do not couple the pump and motor shafts rigidly. Allow freedom at the coupling for the two shafts to ride independently.

To prevent end loading, the space between the pump and motor shaft ends should be 3/4 inch (19.1 mm) for PVR50 pumps, or as the coupling manufacturer specifies.

PIPING AND RESERVOIR

The pump should be mounted with a minimum number of elbows or fittings. The pump suction should be at least two (2) inch (50.8 mm) tube/pipe for PVR50 pumps and 2-1/2 inch (63.5 mm) tube/pipe for PVR50-70B pumps.

For any system and combination of piping except High Water Based Fluids (HWBF), the vacuum at the pump inlet must not exceed seven (7) inches of Mercury, (5 inch Hg. for fire resistant fluids). HWBF Pumps are to have a positive inlet head in the range of 0.5-inch Hg. to 20 inch Hg.

Piping should be done with pickled pipe or seamless tubing free of dirt and scale. Do not use galvanized or other pipe that tends to flake off.

A 100-mesh screen (60 mesh for fire resistant and HWBF) should be used on the pump suction line. The screen should be located approximately two (2) inches (50.8 mm) from the bottom of the tank. All lines returning oil to the tank should discharge at least two (2) inches (50.8 mm) below the minimum oil level and should be separated from the pump suction area by means of a baffle. These lines should also include a 10-micron return line filter, with the exception of the case drain line.

The pump case drain should be connected directly to the tank. Pressure in excess of 10 psi (.7 bar) in the case drain line can result in shaft seal leakage. It is recommended that the case drain be returned to the tank by a separate 1/2-inch (12.7 mm) minimum inside diameter line.

STARTUP PROCEDURES

The following instructions apply for initial start-up of the hydraulic pump. After an extended shutdown period, start with item 5.



CAUTION - Never start a new pump installation against a blocked system.

1. Check the nameplate for model number and rpm. The arrow on the pump casting and/or nameplate indicates direction of rotation.
2. Pump suction line should extend below the lowest point of oil level but not less than two (2) inches (50.8 mm) above reservoir bottom.
3. The pump and motor shafts must be aligned within .003 inches (.08 mm). (See Pump Drive and Mounting directions above for restrictions).
4. Connect the case drain directly to tank (or to a heat exchanger if the pump will be deadheading for long periods of time during operation) using a full-size line corresponding to the case drain in the pump or manifold. If connected to a heat exchanger, the case drain line should be protected with a 10 psi (.7 bar) maximum relief valve in parallel with the heat exchanger. No other return lines should be connected in common with the case drain return.

5. Rotate pump and motor by hand to insure free rotation.

6. Set the machine controls to open the circuit and allow free flow from the pump back to tank or connect the pump outlet line directly to tank. Jog the motor on and off several times (on two seconds; off three seconds) until the pump is primed. Check pump for proper direction of rotation during the jogging.

7. After the pump has been primed, run it for several minutes at lower than normal pressures with an open or intermittently open system which permits oil flow. This will purge entrapped air from the pump and system.

8. Neither volume adjustment nor pressure adjustment should be adjusted until the pump has been primed and running, and air is purged.

9. After air has been purged from the system, the system can be closed and the pump adjusted to the required operating pressure.

10. If necessary, the volume adjustment can be adjusted to limit maximum output to the desired amount.

11. When replacing pumps, the suction screen in the reservoir must be removed and thoroughly cleaned. Also, the suction line from the reservoir to the pump should be flushed inside and out to remove any contaminants. Pieces of metal from a damaged pump can back up into this line. If they are not removed, they will be drawn into the new pump and destroy it. Start unit by using proper pump start-up procedures as previously stated.



CAUTION - If both pressure and volume modifications are supplied on the pump, the pressure should be adjusted before the volume. Volume should be adjusted at minimum pump pressure or at deadhead. Stop adjustment at the volume screw when pressure begins to drop.

OPERATION

PRESSURE AND VOLUME ADJUSTMENTS

Pressure Control

All pumps (except those with special volume or pressure requirements) are adjusted to reduced pressure before shipment and must be readjusted to the required system pressure after installation and start-up.

The pressure adjusting screw is located at the end face of the compensator chamber. See parts page item number 30. The adjusting screw has a right hand thread; clockwise adjustment of the screw increases the pressure; counterclockwise adjustment reduces the pressure.

A pressure gauge located at the pump must be used when making adjustments to ensure the pressure settings do not exceed limits specified for the particular pump or maximum system pressure.

Make all pressure settings with pump operating against a closed circuit, that is with the output of the pump blocked, and then check pressure throughout the pump flow range.

Volume Control

Adjust volume at minimum pump pressure or at pump deadhead. The volume adjusting screw is directly opposite the pressure adjusting screw, see parts page item number 29. The adjusting screw has a right hand thread, turning the screw clockwise decreases the maximum volume, turning the screw counterclockwise increases the maximum volume. Pumps are set at maximum rated volume at the factory unless otherwise specified.

Stop adjustment of the volume screw when pressure begins to drop. See Sales Catalog for complete pump performance specifications.

ADJUSTMENT PROCEDURES

To adjust the maximum output volume, use the following steps:

1. Set the pump at minimum pressure.
2. Hand-tighten the volume screw until it touches the pressure ring. **NOTE:** The pump should be at full flow for this step.
3. See Pressure and Volume Adjustment Sensitivity chart below.
4. Deadhead the pump, then turn the volume screw the proper number of turns to obtain the flow desired.
5. Return pump to flow condition and check flow rate. If output flow is incorrect, switch pump to deadhead and readjust per above.



CAUTION - Turning the maximum volume control in too far can force the pressure ring over-center and destroy the pump.

PRESSURE and VOLUME ADJUSTMENT SENSITIVITY

		PUMP SIZE	32A15	42A15	50B15	70B15
PRESSURE ADJUSTMENT	Press Change/Turn	psi (bar)	115 (8.0)		135 (9.4)	
	Max. Torque	ft./lbs. (kg/m)	26.5 (3.7)			
VOLUME ADJUSTMENT	Flow Change/Turn	gpm (lpm)	14 (53.0)		22 (83.0)	
	Min. Flow Adjust.	gpm (lpm)	6.0 (22.7)	8.0 (30.3)	9.5 (36.0)	12.5 (47.0)
	Max. Torque	ft./lbs. (kg/m)	28 (3.9)	16 (2.2)	28 (3.9)	16 (2.2)

PVR50 KIT LIST (Refer to Drawing and Parts List)

WEAR PLATE KIT	
Includes Items: 4, 5	
Model	Kit No.
32A	133046
42A	133047
50B	142209
70B	162073

SEAL KIT	
Includes Items: 13, 14, 15, 16, 17, 24, 25, 58, 59, 86, 87, 88 and seals for the Volume Adj. and Pressure Adj. Screws	
Model	Kit No.
All Buna-N	124411
All Viton	256826

ROTATING KIT		
Includes Items: 3, 6, 21		
Model	Code	Kit No.
32A & 50B		127748
42A & 70B		133048
32A & 50B	13	143735
42A & 70B	13	143736
32A & 50B	21	252295
42A & 70B	21	Consult Factory
32A & 50B	22	252415
42A & 70B	22	252414

VANE KIT	
Includes Item: 7	
Model	Kit No.
All Models	256803

COMPLETE REBUILD KIT		
Includes Items: All Kits Listed		
Model	Code	Kit No.
32A		256804
42A		256805
50B		256806
70B		256807
32A	13	256808
42A	13	256809
50B	13	256810
70B	13	256811
32A	21	Consult Factory
42A	21	256813
50B	21	256814
70B	21	256815
32A	22	256816
42A	22	256817
50B	22	256818
70B	22	256819

PVR50 PARTS DRAWINGS

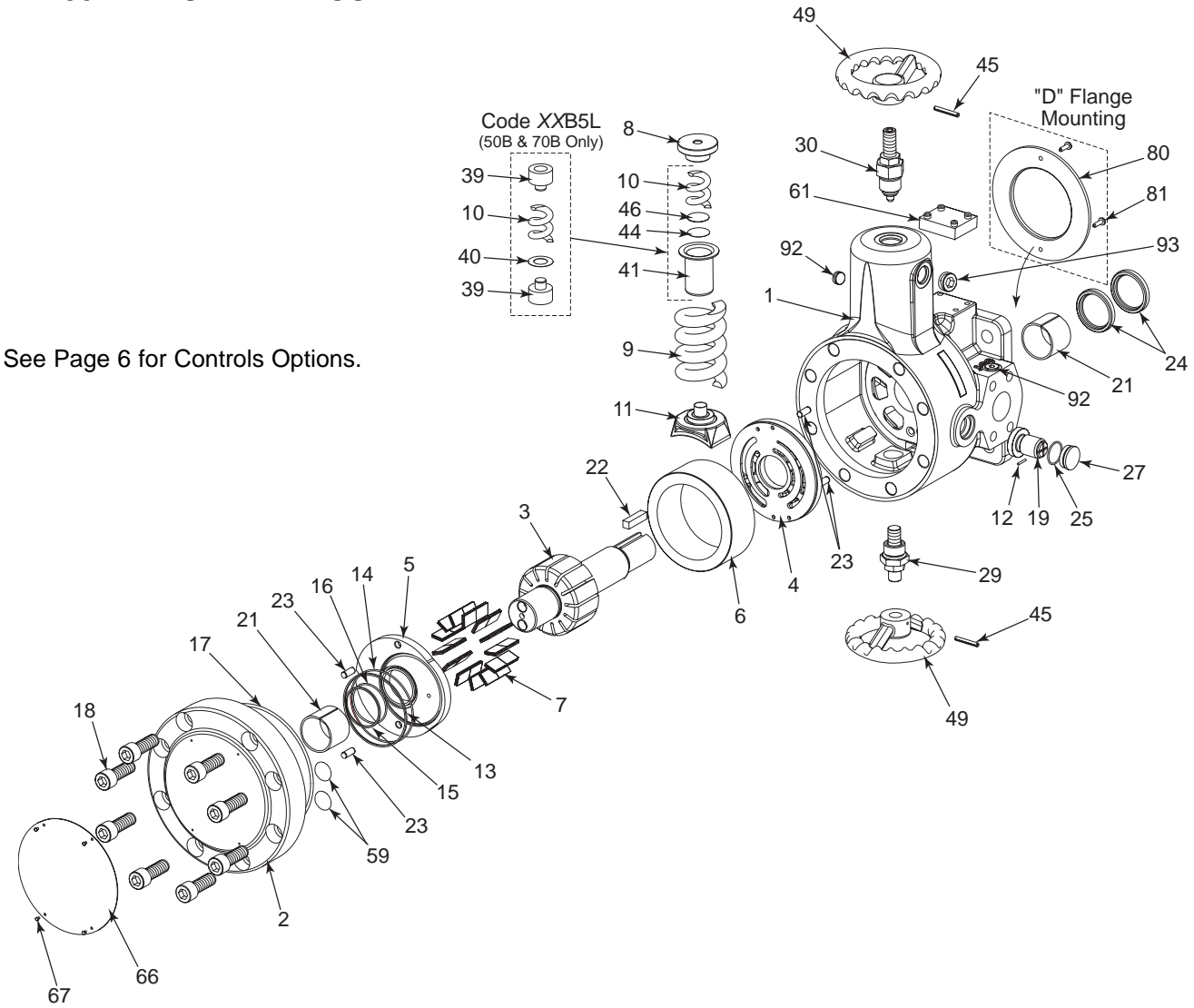

See Page 6 for Controls Options.

Mechanical Options

- Code 13** Double End Drive Shaft
- Code LF** Left Hand Rotation (counterclockwise) (Not Shown)

- Code 21** Tandem Pump Mounting; 9 Tooth Spline, "A" Mounting
- Code 22** Tandem Pump Mounting; 13 Tooth Spline, "B" Mounting
- Code 23** Tandem Pump Mounting; 14 Tooth Spline, "C" Mounting
- Code 31** Tandem Pump Mounting; 13 Tooth Spline, "A" Mounting

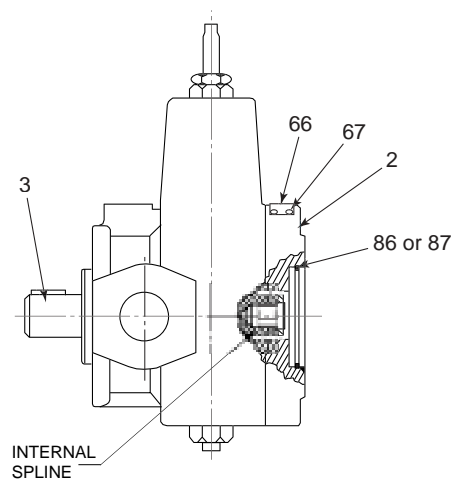
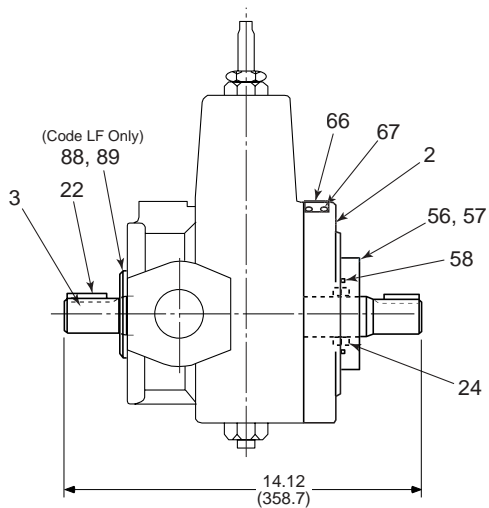

PVR50 PARTS LIST

ITEM NO.	CODE	PART NO.	DESCRIPTION	QTY REQ'D	ITEM NO.	CODE	PART NO.	DESCRIPTION	QTY REQ'D
1	32A, 42A, 50B 17, 21, 22, 2400, 2500	550615	Pump Body (Std.)	1	30		250240	Pressure Adj. Screw Ass'y.	1
1	18**, 24**, 25**	550641	Pump Body (Std.)	1	31	8, 9	256509	O-Ring Union	1
1	17, 21, 22, 2400, 2500	550640	Pump Body ("D" Mounting)	1	32	8, 9	256508	Flow Control Valve	1
1	18**, 24**, 25**	550642	Pump Body ("D" Mounting)	1	33	2400, 24**, 2500 25**	350945	PMA-24B-A	1
1	70B 17, 21, 22,	550616	Pump Body (Std.)	1	34	18**, 24**, 25**	256510	Flare Connector	2
1	18**, 24**, 25**	550617	Pump Body (Std.)	1	37	24**	256889	Hydraulic Hose (20")	1
1	17, 21, 22,	550618	Pump Body ("D" Mounting)	1	39	5L	255592	Spring Guide	2
1	18**, 24**, 25**	550619	Pump Body ("D" Mounting)	1	40	5L	123186	Shim (.010)	A.R.
2	32A, 42A, 50B	500124	Cover (Standard)	1	41		308691	Spring Retainer	1
2	13, LF	500230	Cover	1	44	32A15, 42A15, 50B15, 70B15	163786	Shim (.010)	A.R.
2	21, 31	508451	Cover	1	45	15, 36	004262	Roll Pin	1
2	22	508441	Cover	1	46	32A15, 42A15, 50B15, 70B15	257850	Shim (.060)	A.R.
2	23	550930	Cover	1	48	25**	256514	O-Ring Run Tee	1
2	70B	504897	Cover (Standard)	1	49	15, 36	301737	Handwheel	1
2	13, LF	507588	Cover	1	50	18**, 24**, 25**		Valve (Ref.- See Valve Escutcheon for Model)	1
2	21, 31	550171	Cover	1	51	17, 1800, 18**, 2500, 25**	350946	PMA-17B-A	1
2	22	550139	Cover	1	52	18**, 25**	256888	Hydraulic Hose (16")	1
2	23	550928	Cover	1	53	25**	256894	Hydraulic Hose (28")	1
3		550184	Rotor Shaft	1	56	13, LF	401995	Seal Retainer	1
3	13	550295	Rotor Shaft	1	57	13, LF	198278	Soc. Hd. Cap Screw	3
3	21	550183	Rotor Shaft	1	58	13, LF	111298	O-Ring	1
3	22, 31	550296	Rotor Shaft	1	58	Viton	112222	O-Ring	1
3	23	550944	Rotor Shaft	1	59	70B	260411	O-Ring	4
4	32A	402001	Port Plate	1	59	Viton	109780	O-Ring	4
4	42A, 70B	404384	Port Plate	1	61	1800	210721	MC03-A Cover Plate	1
4	50B	404418	Port Plate	1	66		259077	Escutcheon	1
5	32A, 42A, 50B	503335	Thrust Plate	1	66	13, 21, 22, 23, 31, LF	259091	Escutcheon	1
5	70B	504899	Thrust Plate	1	67		250597	Drive Screw	4
6	32A, 50B	034460	Pressure Ring	1	69	23	450720	Adapter	1
6	42A, 70B	302221	Pressure Ring	1	70	23	199682	Hex. Hd. Cap Screw	6
7		256803	Vane Kit	1	80	"D" Mtg.	350810	Adapter Ring	1
8		308439	Spring Seat	1	81	"D" Mtg.	198820	Pan Hd. Mach. Screw	2
8	3L, 5L	307853	Spring Seat	1	82*	21, 23, 31	008446	Cap Plug	2
8	17, 18**, 2500 25**	351188	Spring Seat	1	83	18**, 24**, 25**	198225	Soc. Hd. Cap Screw	4
9		262957	Governor Spring	1	84	18**, 24**, 25**	012144	Lockwasher	4
9	3L, 5L	114414	Governor Spring	1	85	21, 23, 31	147655	Flange Cover	1
9	32A15, 42A, 70B	129143	Governor Spring	1	85	22	164598	Flange Cover	1
10		162823	Spring	1	86	21, 23, 31	120689	O-Ring	1
10	42A15, 70B	162824	Spring	1	86	Viton	141714	O-Ring	1
11		122404	Ring Shoe Assembly	1	87	22	146493	O-Ring	1
11	42A15, 70B	130582	Ring Shoe Assembly	1	87	Viton	154132	O-Ring	1
12		130041	Pin	1	88	LF	147177	O-Ring	1
13		120805	Teflon Seal Ring	1	89	LF	350179	Pump Bolt Plug	1
14		121619	O-Ring	1	90*		254832	Flange Protector	1
14	Viton	130608	O-Ring	1	91*		254833	Flange Protector	1
15		122340	Teflon Seal Ring	1	92		256708	O-Ring Plug (Viton) (Add 1 - Code 1800, 2400, 2500)	1
16		130607	O-Ring	1	93		256744	Cap Plug	1
16	Viton	130609	O-Ring	1	94	22	008345	Cap Plug	2
17		108991	O-Ring	1	94	23	119799	Cap Plug	2
17	Viton	110134	O-Ring	1	95*	70B	258775	Loctite #262	A.R.
18		198324	Soc. Hd. Cap Screw	8	97*	21, 22, 23, 31	258693	Spline Warning Tag	1
19		302127	Thrust Screw	1	98*		143391	Grease	A.R.
21		121090	Bearing Bushing	2	99*		132779	LED Plate #250	A.R.
22		012137	Key (Add 1 - Code 13)	1	* These Items Are Not Shown				
23		260380	Dowel Pin	4					
24		121600	Lip Seal	2					
24	Viton	122169	Lip Seal	2					
25		153111	O-Ring	1					
25	Viton	162100	O-Ring	1					
26*	70B	123328	Pipe Plug	2					
27		250368	Thrust Screw Plug	1					
29		256486	Volume Adj. Screw Ass'y.	1					

PVR50 PARTS DRAWINGS

Control Options

Code 17 Dual Pressure Control Without Integral Valve

Code 18** Dual Pressure Control With Integral Valve

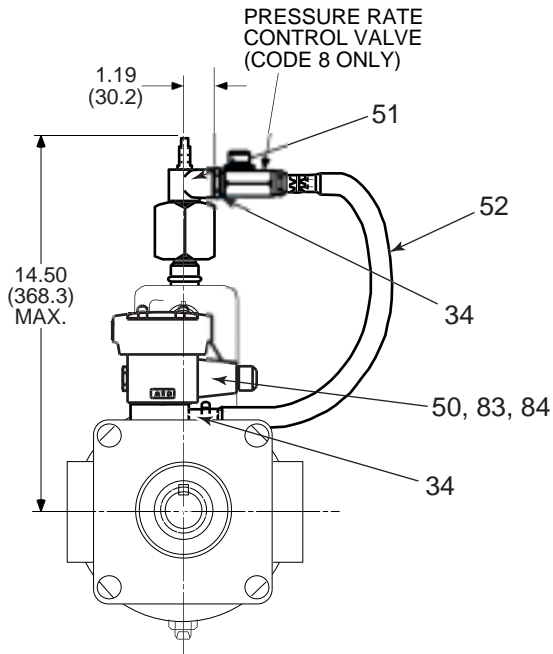

Code 2400 Dual Volume Control Without Integral Valve (32A, 42A, and 50B Only)

Code 24** Dual Volume Control With Integral Valve

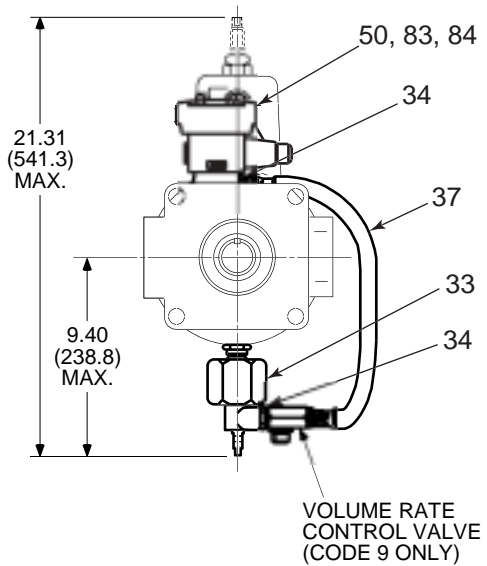

Code 2500 Dual Pressure/Volume Control Without Integral Valve (32A, 42A, and 50B Only)

Code 25** Dual Pressure/Volume Control With Integral Valve

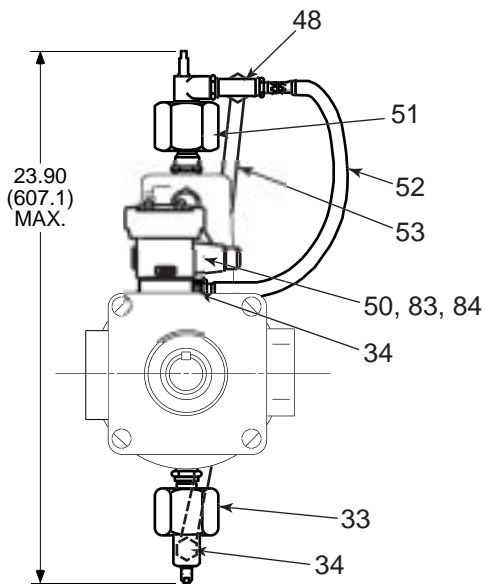

Code 8 Rate Control Valve for Dual Pressure

Code 9 Rate Control Valve for Dual Volume

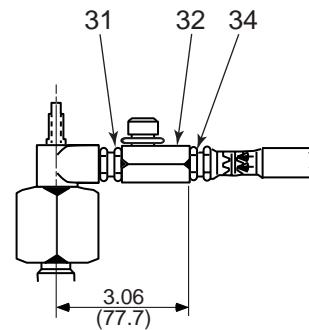

NOTE: Install #34 on Code 17 and 18** Only (Code 8 Only).

PVR50 PUMP REPAIR PROCEDURES

DISASSEMBLY PROCEDURE



NOTE: Disassembling pump to change components, or for any other reason, may void the warranty. Refer to Policy Statement and Discounts Summaries.

1. Remove the key (22) in the rotor shaft keyway.
2. Remove the eight cover bolts and slide the cover back far enough on the shaft to break the seal between the housing and cover to allow the pump to drain. A small amount of oil may remain in the pump.
3. Remove the cover. Take care to avoid damage to the bearing with the end of the shaft when the cover is removed.
4. The port plate (4) may come out with the cover. Do not let it drop off the locating pins.
5. Remove the vanes (7) with a long nosed pliers or tweezers. There are four vanes in each slot, 52 vanes total.
6. Remove the rotorshaft (3) from the pump. Be sure that the key (22) has been removed from the keyway so that it will not damage the shaft seals when the rotorshaft is removed.
7. Turn the pressure adjustment screw (30) counterclockwise to release the tension on the governor spring.
8. Remove the pressure ring (6), ring shoe (11), governor spring (9), retainer (41) and spring (10).
9. If the shaft seals (24) are to be removed they should be pushed out from the inside of the housing at this time. Care must be taken not to damage the bearing bushing (21) in the housing while the shaft seals are being removed. It is recommended that the shaft seals be replaced whenever the pump is disassembled for maintenance. The seals cannot be reused once they have been removed.
10. The bearing bushing (21) in the pumps are assembled with a press fit. If they are to be removed at this time, the bearing in the housing should be pressed out from the front. The cover bearing should be pulled out using an expanding type puller. The bearings should not be reused once they have been removed.
11. It is unlikely that further disassembly will be necessary in order to perform routine maintenance on the pump.

REASSEMBLY PROCEDURE

1. Clean and inspect parts to determine which parts are worn enough to require replacement.
2. Assemble the new bearings (21) in the housing and cover. The bearing OD's should be lubricated before they are pressed in the bores. Care must be taken to orient the "split" and the "oil groove" in the bearing as shown in the illustration below.

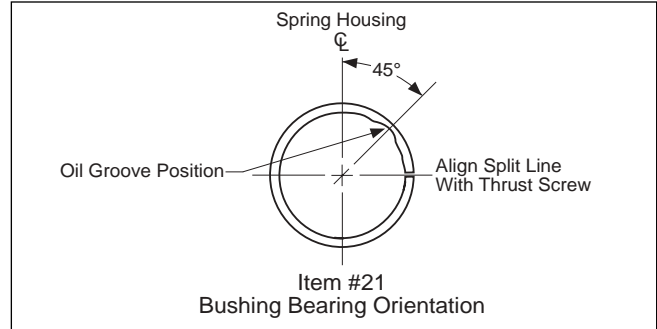

3. After the bearings are in place, check to see that the rotor shaft (3) will fit into the bearings and provide a smooth turning fit. If the shaft turns hard, the bearings should be removed and the bores checked closely for nicks or burrs before pressing in the new bearings.
4. Check all of the replacement parts for nicks or burrs and then lubricate them with clean oil before reassembly.
5. Worn port (4) and thrust plates (5) should not be reground to clean up the wear surface. If the plates are ground, the assembly clearance will become excessive and the seal rings in the thrust plate may rupture. Replace worn port and thrust plates if necessary.
6. Assemble the port plate (4) on the locating pins (23) in the body housing. If the bores are not concentric, the port plate must be rotated 180° on the locating pins.
7. Assemble the springs (9 and 10) and ring shoe (11), pressure ring (6) and rotorshaft (3).
8. To assure proper vane assembly, place the vanes (7), four per slot, with the beveled edges facing each other and against the pressure ring.

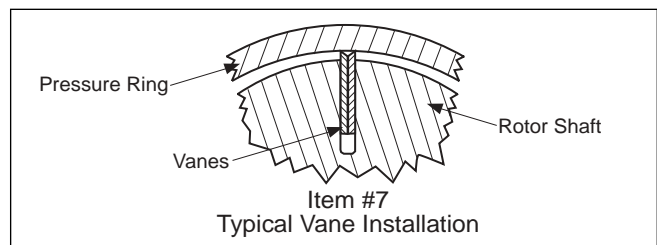

9. Install the o-rings (14 and 16) into the thrust plate (5) first and the square teflon seal rings (13 and 15) should be assembled on top of them. Stretch the larger soft seal ring slightly so it clings to the OD at the cavity. Apply clean oil or STP to the back of the thrust plate before it is placed on the locating pins in the cover to help hold the parts together while they are assembled.

10. Before lifting the cover into the housing, check to assure that the bore in the thrust plate is concentric to the bearing bore in the cover. If the bores are not concentric, the thrust plate must be rotated 180° on the locating pins.

11. Assemble the cover (2) and thrust plate (5) onto the housing (1) and align the bolt holes. Rotate the shaft as the cover bolts (18) are tightened to assure that the vanes are not cocked.

12. Torque the cover bolts to 100 lbs-ft. The shaft should turn by hand when assembly is complete.

13. Lubricate the ID of the shaft seals (24) and press it into the housing to the depth shown below. Note the "lips to the inside" orientation of the seals.

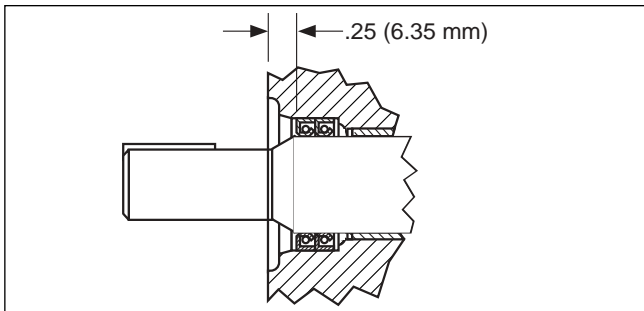

14. Adjust the pressure adjustment screw (30) until it just touches the spring and then give it one more turn clockwise.

15. Turn pump upside down. Pour one cup of good grade hydraulic fluid into the intake port while slowly rotating the shaft in the direction shown by the rotation arrow.

16. The pump is now ready to test. Refer to front of this manual for start-up procedure.

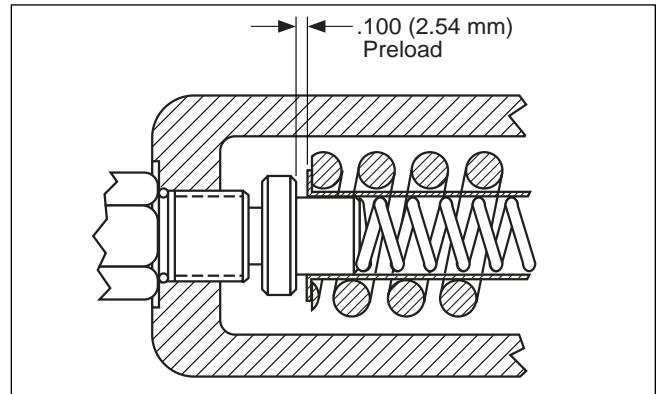

Continental Hydraulics
12520 Quentin Avenue South
Savage, MN 55378
Phone: (952) 895-6400 Fax: (952) 895-6444
www.continentalhydraulics.com

Because Continental Hydraulics is continually improving its' products, specifications and appearance are subject to change without notice.