



# FOURSIGHT

ISSUE TWO 2020

NEWS & INSIGHTS INTO THE WORLD OF CONTINENTAL



## Show and Tell



North America's  
Largest Construction  
Trade Show Las Vegas, NV.  
March 10-14, 2020

ConExpo 2020 is just around the corner and Continental is ready and able to show the new products and services you've been waiting for at the International Fluid Power Expo (IFPE) South hall 3 building.

With emerging products and technologies, together with our mobile division Hydreco, we're putting on a show to remember! Our presence at ConExpo is a continued investment and commitment toward the delivery of innovation and value to our customers and markets.

Come and meet the team that set out to make your life easier with our engineering excellence and application know-how. We'll be there to have conversations around the technical issues you're facing and the opportunities

**Continental/Hydreco** gets you a discount on CONEXPO registration.  
**Deadline Jan 17 for \$79**  
Advanced price \$149 - Standard price \$179  
Includes admission, show/hotel shuttle and seven day monorail pass.  
Use Promo Code: **EXc7qhhvCST**  
at [www.conexpoconagg.com](http://www.conexpoconagg.com)



Roger Warnock - Continental South West Regional Sales Manager

## ▶ Fluid Power Ranger

My superpower has been working with fluid power for over 30 years. Including roles from technician, to inside sales, to outside sales, to engineering, and now as a south west regional sales manager.

Fluid power has given me a wonderful opportunity to work in all sorts of industries and applications. I have been on everything from subsea application 5000 meters below the ocean floor to rocket launch systems. Even lucky enough to be named on a couple of patents.

I love working and being a part of Continental Hydraulics. We have great people, quality products, excellent systems integration capabilities, and a global presence with small company responsiveness. I have made lifelong friends and been able to see some really unique applications. The level of skill and creativity in my teammates and customers is truly awe inspiring.

Fluid power is changing and in early stages of a technological revolution

Continental Hydraulics, part of Duplomatic Motion Solutions group, is poised to be at the forefront of this revolution. We are a growing family of complimentary companies within a strong, secure global group. We are empowered to be creative and innovative, sized to be nimble and responsive, and capable of facilitating our customer's successes through superior motion technology components, systems and integrated solutions.

Contact us with your most challenging application, and let us show you how our products, people, and partners can help you join the motion solutions revolution.

*Roger Warnock*



Booth #S81217

Continental's  
4 Pillars of Difference

▶ Engineering Excellence    ▶ People Who Care    ▶ Application Know-How    ▶ Easy To Do Business With

Turning innovative products into dynamic solutions for force and motion, hydraulics and electrical systems. ▶

## ► We're in the Forestry Industry

Engineered to provide robust, flexible and custom solutions to keep you up and running.

Our customers tell us that reducing downtime is their number one issue. That's why absolute reliability is so important to maintain productivity and efficiency. At Continental we're your partners. We work with you to achieve the product performance that you need and deserve when moving or processing timber.

Our advanced control technology within our valves allows for flexibility and configuration to ensure high performance under heavy and constant loads.

## ► Flexing our electric muscles

Flexibility of electric actuators brings added value in terms of power saving (electric cylinder consumes one tenth the power absorbed by a pneumatic one). Including an increase in productivity (thanks to reduction of working times and production downtimes) plus smart controls and versatility. Hygienic clean design for applications in clean rooms and food and beverage machines.

Air pipes are, in fact, replaced by electric cables, without the need for manifolds and FRL (filter regulator lubricator) groups. The electric actuators produce customized solutions, even for a single piece and offers the possibility to fit customers' motors on the cylinders. Other benefits in terms of flexibility are the wide range of motors available, the three types of bearing stacks depending on the application, the different types of screws for motion transmissions. All cylinders can be equipped with in-line or parallel motors.

### ECS3 Standard Plus

Sizes: 32-50-80  
Max: Axial force: 20,000 N  
Speed: 1,300 mm/s  
Stroke: 1,400 mm

### ECS4 Power

Size: 80  
Max: Axial force: 50,000 N  
Speed: 800 mm/s  
Stroke: 1,400 mm

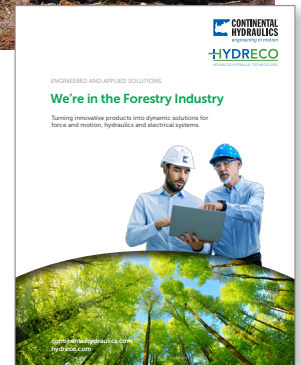
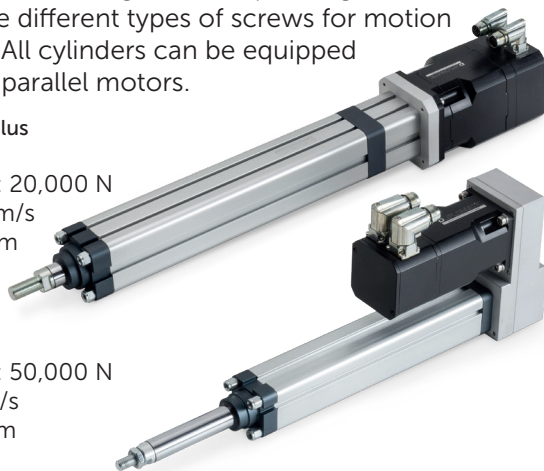

Posters and Brochures

Customers today expect and need solutions that make their daily operations simpler, more flexible, faster, more reliable and affordable. At Continental we respond to these challenges and build-in the technology and expertise that exceed these demands.

Continental draws on rich engineering experience and in-depth expertise to create smart solutions that allow customers to anticipate any given situation and react swiftly to them..

Relax in the knowledge that Continental has your fluid power applications under control.

## ► Levelling up!

**Application:** Enhanced Levelling Technology

**Customer:** Coil and sheet metal processing company in Pennsylvania

**Product:** Custom Power Unit

Enhanced levelling is the new benchmark in producing stay-flat material and addresses the problem of un-uniform (trapped) strain in sheets that have been correctively levelled. This is done through a unique combination of very severe and uniform bending.

The end result is reliably consistent, repeatable and verifiable flat material that stays flat. Sheet to sheet, coil to coil for the most critical end user applications, materials that must stay flat during fabrication cannot have dissimilar internal strain. Enhanced Levelling Technology is the most consistent and reliable method of producing homogeneous stay-flat material for the most demanding applications.

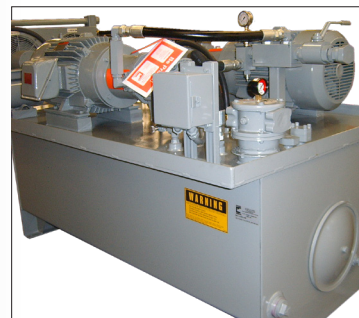

### CONTINENTAL HYDRAULICS INC.

4895 12th Avenue East, Shakopee, Minnesota 55379

T 952-895-6400

F 952-895-6444

E sales@conthyd.com [www.continentalhydraulics.com](http://www.continentalhydraulics.com)