



ENGINEERED AND APPLIED SOLUTIONS

We're in the Food & Beverage Industry

Turning innovative products into dynamic solutions for force and motion, hydraulics and electrical systems.



Solutions for Food & Beverage

The truth is in the pudding

Continental Hydraulics products are engineered to provide robust, flexible and custom configured solutions, to keep you up and running.

Food, beverages, and hydraulics all have one thing in common: the need for cleanliness. Contamination isn't an option, and that's why hydraulic components, such as hydraulic cylinders, must be manufactured out of stainless steel. And not only do these components need to be sanitary, they also need to be able to function under a wide variety of conditions, such as high temperatures, pressures, and speeds.

At Continental we know this industry well, as we have helped many customers through the years improve their efficiencies while making great savings overall. We work with customers in industries where high-performance motion control and fluid power solutions are critical for success.

Let Continental help you. Speak to our team to ensure downtime is reduced and your confidence in your requirement higher than ever with our support.

Applications

- Conveyors
- Kill Floors/Slaughter Houses
- Dump Systems
- Packaging Machines
- Lifting/Lowering
- Filling/Sealing Processes



Food & Beverage Industries

- Bottled and canned (soft drinks and water)
- Breweries/Wineries
- Dry, condensed, evaporated dairy product manufacturing
- Flavouring syrup and concentrate manufacturing
- Roasted Nuts and peanut butter manufacturing
- Confectionery manufacturing from purchased chocolate
- Cheese manufacturing
- Seafood/Pork/Beef/Poultry
- Processing and Packaging
- Vegetables
- Grains/Bread
- Frozen/Processed foods
- Pet food
- Poultry
- Meat Processing directional control / proportional control / servo-proportional control

Food & Beverage Technologies

- On-board and off-board proportional valves
- Open and closed loop solutions
- IO Link and field-bus options
- Mono block / sectional mobile valves to 120 GPM
- Variable and fixed displacement pumps to 5000 PSI

Hydraulic Variable Volume Vane Pumps

Unique characteristics allow vane pumps to outperform most other pump designs in systems with fluids that typically have minimal performance properties required by most hydraulic pumps for long trouble-free life, the vane pump is the best choice.

The advantages of vane pumps:

- Pressures to 3000 PSI and flows to 75 GPM
- Vane pumps are self-priming and robust.
- Contamination and lubricity tolerant
- Their vanes are self-compensating for wear and designed for serviceability.
- Volumetric and overall efficiencies are high.

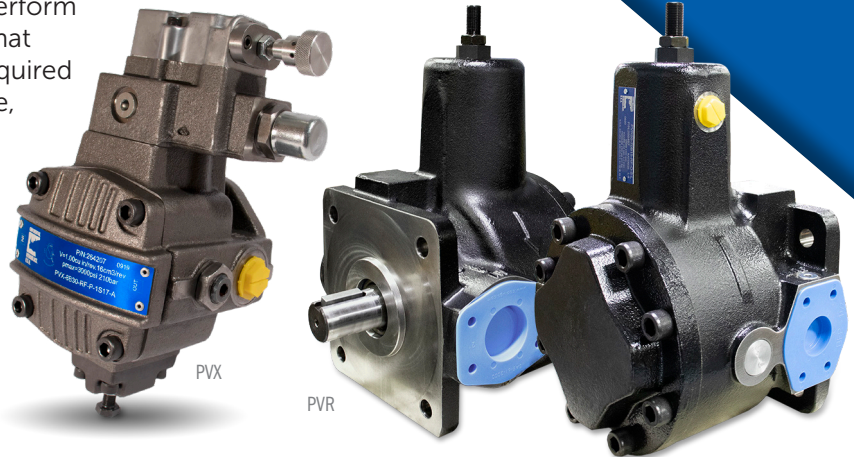

Directional Control and Monitored Valves

Available in both proportional and on/off control, the Continental valves are available with a variety of coil voltages and connections types with up to IP69 ratings. Valve body coating available with zinc-nickel surface treatment for wash-down environments.

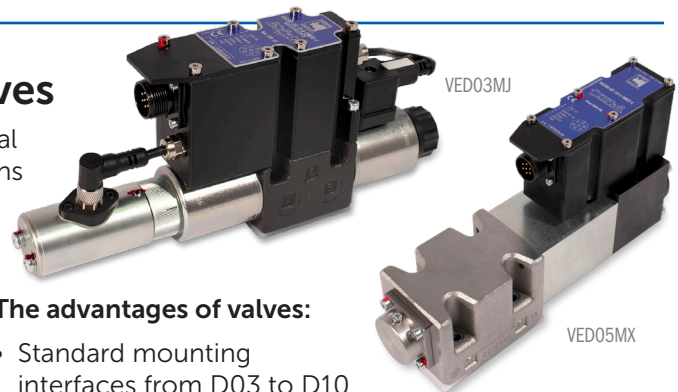

The advantages of valves:

- Standard mounting interfaces from D03 to D10
- Variety of connections Conduit Box, DIN, Deutsch, Manual, Pneumatic and Hydraulic actuation as well as hazardous Location rated coils.
- Pressure to 5000 PSI and flows to 300 GPM
- IO-Link options for improved performance and predictive maintenance.

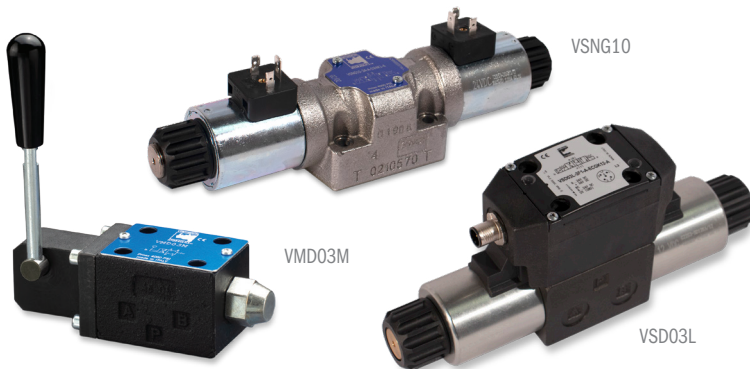

Dual monitored, for your safety circuits:

Monitored valves and dual monitoring block and bleed kits, are designed to assist in meeting safety requirements listed in ISO 13849 and EN 692 directives. These components when properly implemented into the safety control system can help you achieve the required level of safety your equipment may require.

The advantages of monitored products:

- Single or dual position sensor signals
- Zinc-Nickel and electro-less nickel plating's are ideal for wash-down environments to IP66
- Dual Monitoring Kits incorporate two separate valves on a unique Series / Parallel manifold
- D03 and D05 Dual Kits include a true 3-way spool design resulting in safer operation at high flows

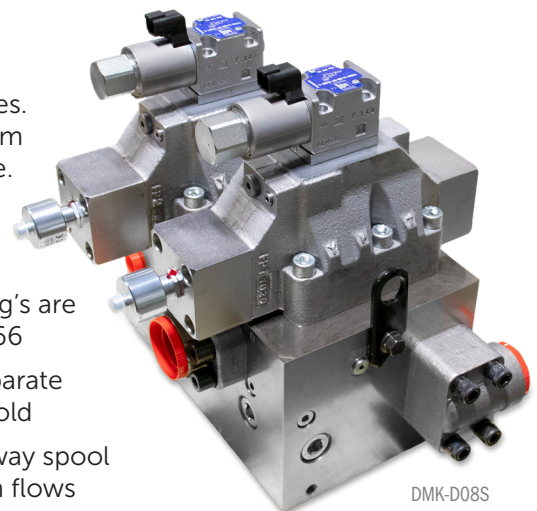
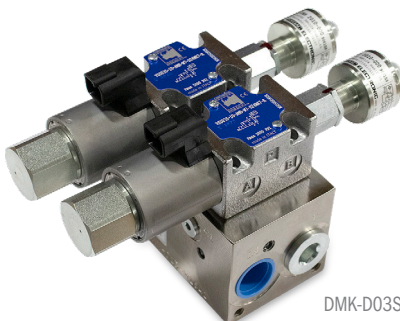

Mobile Products - Agriculture Upstream Food & Beverage

From planting and harvesting or getting it to the processing plants the Hydreco line of pumps, valves, controls, joysticks etc. are the solutions for your mobile applications.

Mobile Directional Control Valves

- Mono-block and sectional designs
- Parallel, tandem and mixed circuit options
- Manual, hydraulic, pneumatic and electro-hydraulic operators available
- Flow ranges up to 120 GPM, pressures to 5000 PSI
- Range of spool types and metering characteristics

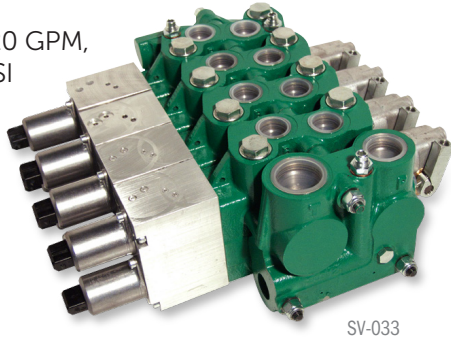

SV-033



Pilot Control Valves

- Remote pilot operation of directional valves with user-friendly, low effort controls
 - Single and multiple joystick controllers
 - Hand or foot pedal designs
 - Ergonomic designs



HY076



Handles, Pedals and Joysticks

- Multi-function ergonomic handles with extended button areas
- Analogue, PWM and CAN-bus options
- Knobs and levers with or without electrical switches and range of buttons
- On-Off or proportional

Cast Iron Gear Pumps

- Displacements from 0.73 to 14.6 cu.in. and pressures to 5000 PSI
- More tolerant to hydraulic system contamination
- Precision machined shafts and gears made from high strength heat treated steel, 18-teeth gears reduce pressure ripple (noise), improves volumetric efficiency.
- A wide range of mounting flanges, port interfaces and pump combinations

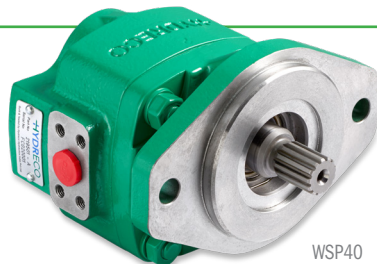

WSP40

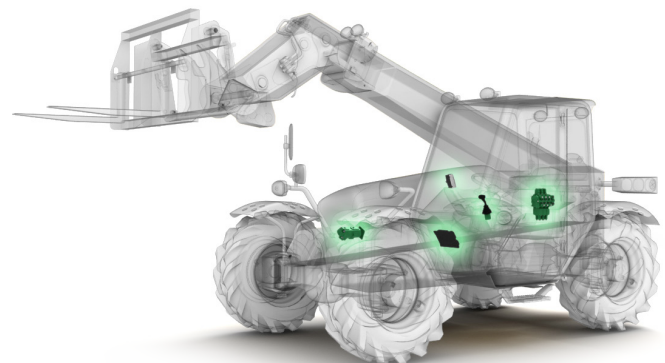

Hydraulic Power Units

Whether you need a small unit for a single function or a large central unit to run the entire plant we are the best solution for your needs.

All Continental Hydraulics' power units are designed to ensure long life and reduced operating costs. Our expertly trained and highly qualified engineers will work with you to recommend the hydraulic system configuration that is best for your company's needs.

The advantages of our Power Units Systems:

- Tank capacity from 3 to 500-gallon tanks (Steel, Stainless Steel, Custom Paints)
- JIC, L-Shape, Overhead or in-tank vertical designs
- Complete turnkey systems with diagnostic and data acquisition if required
- Complete drawings and BOM for approvals or future maintenance
- Flow ranges from 0.5 to 500 GPM and pressures to 5000 PSI



One example of many different size power units that we can make.



Wash-down power unit option:

Provide a power unit base for food industry that require pressurized wash downs

Electric Actuators

When the applications or environments require motion without the use of hydraulics or lubricated air is discouraged, our line of electric actuators are the solution.

The advantages of electric actuators

- Customizable to your situation
- Axial force to 20,000 pounds
- Travel speeds to 50 inch per second
- In-Line or Parallel actuator designs
- Variety of screws and drive motors to your specifications
- Sizes: 32, 50, 63, 80, 100, 125

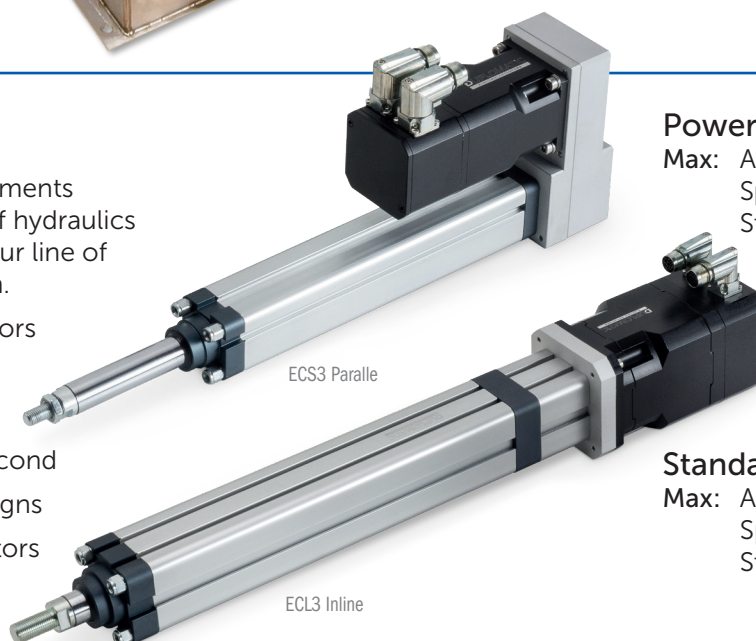

Power - ECS3

Max: Axial force: 50,000 N
Speed: 800 mm/s
Stroke: 1,400 mm

Standard Plus - ECL3

Max: Axial force: 20,000 N
Speed: 1,300 mm/s
Stroke: 1,400 mm

Making the difference at Continental & Hydreco

At Continental, we have built our reputation on these four pillars that make our company different: People who care, who deliver engineering excellence and application know-how, all while being easy to do business with.

From hydraulics to motion solutions, from the Mid-West to the World, from analogue control logics to computerized electronics and AI, we are riding the wave of technology in our fast-changing markets.

Continental has been at the forefront of power transmission innovation for over 60 years and is – a leading force in transforming the industrial world we live in.

4 Pillars of Difference



Global Support

As a member of the Diplomatic Group our distribution and service network is quick, reliable, and responsive to our customer's needs. Rest assured that no matter where you're located, we will be there with unrivalled products and technical expertise.



Technical Support

Quality products are only part of Continental Hydraulics and Hydreco's commitment to our customers. We also provide advisory, planning, and design services specifically geared to your application and backed by on-time delivery, full repair and test facility capabilities.



Exceptional People

Continental engages and inspires their workforce to deliver on our four pillars of difference, providing the very best in what we do. Our culture, like everything at Continental, is made possible by each employee's contribution as a unified team.



PROUD MEMBER OF THE **DIPLOMATIC GROUP**
MOTION SOLUTIONS

CONTINENTAL HYDRAULICS INC. / HYDRECO INC.

4895 12th Avenue East, Shakopee, Minnesota 55379

952.895.6400 • sales@conthyd.com • www.continentalhydraulics.com

704.295.7575 • sales-us@hydreco.com • www.hydreco.com