

# F03MSV-NIPC

**PRESSURE PORT FLOW CONTROL WITH  
 DIRECT OPERATED SERIES CHECK VALVE**

**P** max **5000 PSI 350 bar**  
**Q** max SEE PERFORMANCE TABLE

**MODULAR VERSION  
 NFPA D03 ISO 4401-03**

## MOUNTING INTERFACE

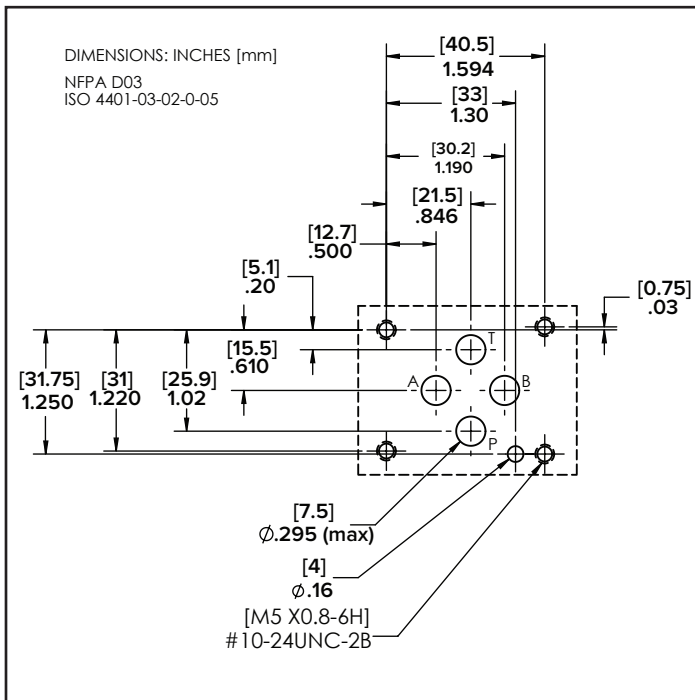

## OPERATING PRINCIPLE

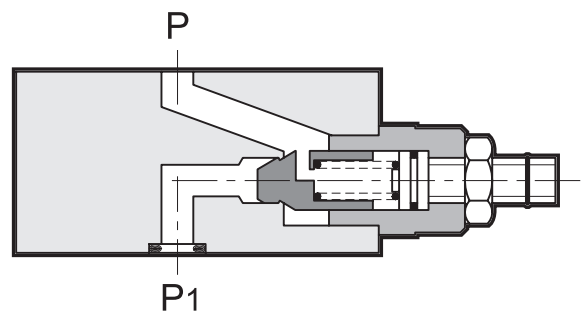

- The F03MSV-NIPC valve is a flow control valve on the pressure port with a check valve in series to prevent back flow.
- It is made as a modular version with mounting surface according to the NFPA D03/ISO 4401-03 standards.
- Typically, it mounts sandwiched between a directional control valve and a subplate/manifold and functions as a flow limiting device.
- It is used when it is necessary to control the flow in one direction and to prevent backflows in the opposite direction.
- Control of the flow is obtained with a socket hex screw and locking nut.

## PERFORMANCES (measured with mineral oil of viscosity 36cSt at 120°F [50°C])

Maximum operating pressure Check valve cracking pressure	PSI [bar]	5000 [350] 14.5 [1]
Maximum flow rate in controlled lines Maximum flow rate in the free lines	GPM [l/min]	13.2 [50] 20 [75]
Ambient temperature range	°F [°C]	-4 to 140 [-20 to +60]
Fluid temperature range	°F [°C]	-4 to 176 [-20 to +80]
Fluid viscosity range	cSt	10 - 400
Fluid contamination degree	According to ISO 4406:1999 class 20/18/15	
Recommended viscosity	cSt	25
Mass:	lbs [kg]	2.4 [1.1]

## HYDRAULIC SYMBOLS

### F03MSV-NIPC

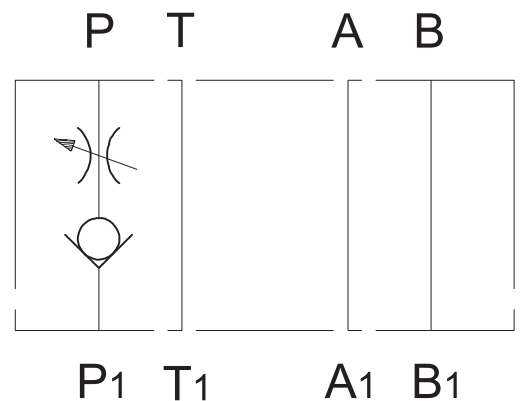

# 1 • IDENTIFICATION CODE

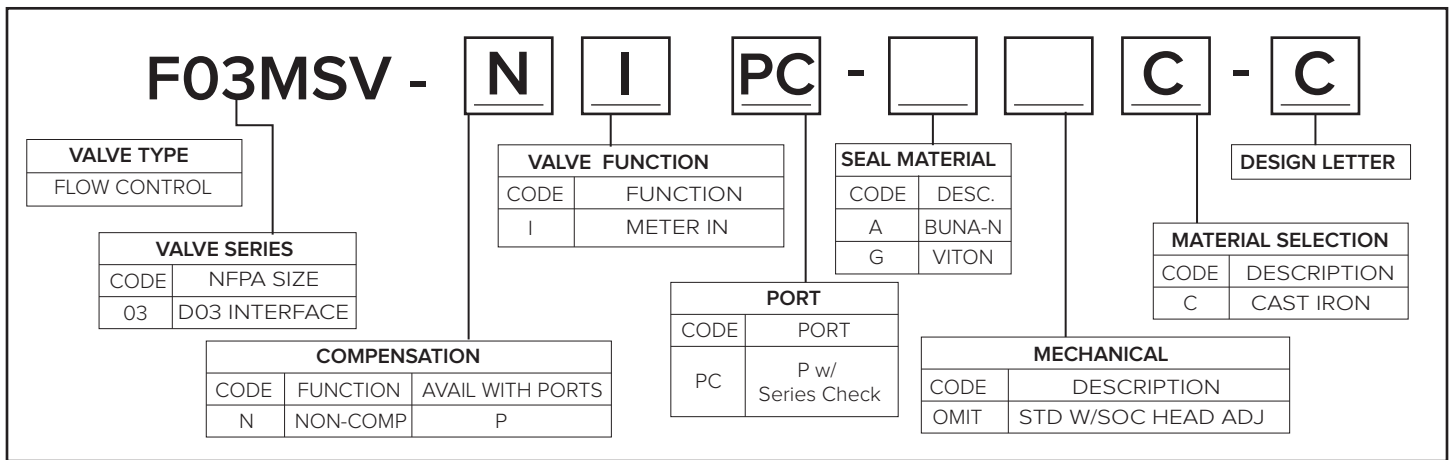

# 2 • CHARACTERISTIC CURVES (values obtained with viscosity of 36 cSt at 120°F [50°C])

- 1) pressure drops on controlled lines
- 2) pressure drops on free lines

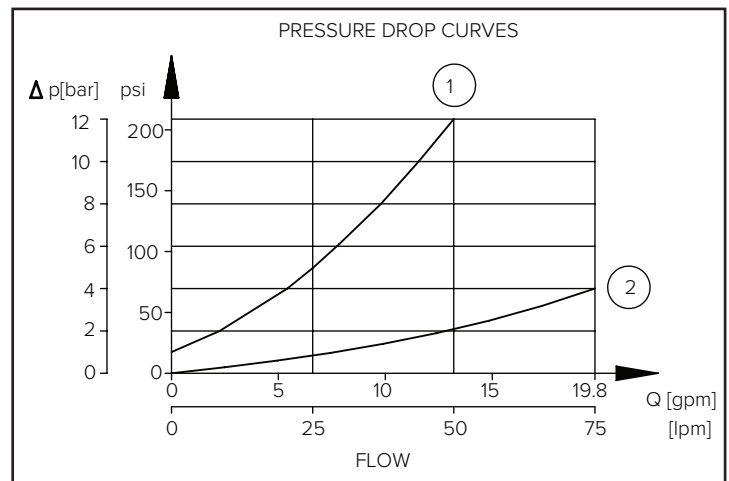

# 3 • HYDRAULIC FLUIDS

Use mineral oil-based hydraulic fluids HL or HM type, according to ISO 6743-4. For these fluids, use NBR seals (code A). For fluids HFDR type (phosphate esters) use FPM seals (code G). For the use of other kinds of fluid such as HFA, HFB, HFC, please consult our technical department. Using fluids at temperatures higher than 176°F [80°C] causes a faster degradation of the fluid and of the seals characteristics. The fluid must be preserved in its physical and chemical characteristics.

# 4 • OVERALL AND MOUNTING DIMENSIONS

