



SERVICE MANUAL

VSD03M Solenoid Actuated Directional Control Valves

“A” Design Series



CAUTION – Before performing any service operation on any Directional Control Valve, be sure that all pressure has been relieved from BOTH SIDES of the system.



CAUTION – Before performing any service operation on any Directional Control Valve, disconnect or lock off power supply.



CAUTION – Before manually actuating any Directional Control Valve, be sure that any resulting machine function will not endanger persons or equipment.

PRODUCT IDENTIFICATION

Each Directional Control Valve has an Ordering Code printed on its cover label. See Figure 1 for the location of the Ordering Code.

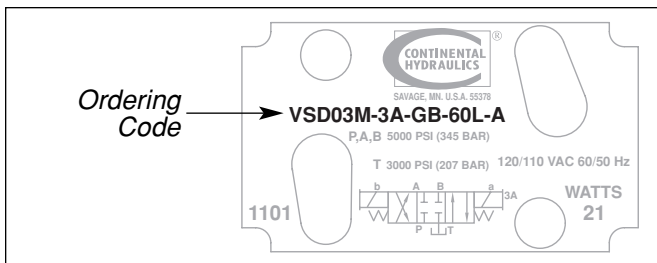

Figure 1

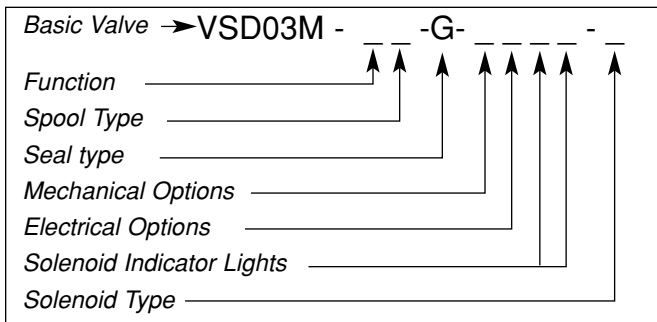

Figure 2

This Service Booklet applies to products with Ordering Codes like the sample in Figure 2

GENERAL SPECIFICATIONS

RECOMMENDED FLUID

Petroleum, water-based fluids (not more than 40% water) and most phosphate esters. Other fluids may be

acceptable, but special O-rings may be required. Viton seals standard.

FLUID TEMPERATURE RANGE

Fluid temperature up to 200° F. will not appreciably affect valve performance. However, for safety reasons, temperatures above 130° F. are not recommended.

RECOMMENDED OPERATING VISCOSITY

80 to 350 SUS.

FILTRATION

ISO 18/16/13 or better.

MOUNTING POSITION

Any unrestricted position acceptable. Horizontal mounting preferred.

NFPA FLOW PATH/ACTUATING PATTERN

SOLENOID, AIR AND OIL ACTUATED:

Actuating operator a – connects flow to cylinder port A.

Actuating operator b – connects flow to cylinder port B.

GENERAL INFORMATION

SOLENOID ACTUATED – Spring centered and spring offset valve types will be spring positioned unless actuated continuously. Detented, no-spring valves may be actuated momentarily. When solenoid is not actuated, the spool will remain in last position attained, provided there is no severe shock, vibration or pressure surge.

Pressure surges in a common tank line serving these and other valves can be great enough to cause inadvertent valve shifting. This is particularly critical in the no-spring, detented type valves. Separate tank lines may be necessary.

NOTE: Any sliding spool valve held shifted under pressure for long periods may stick and not spring return due to fluid residue formation. To prevent sticking, valves should be cycled periodically.

PREVENTIVE MAINTENANCE

After Directional Control Valves have been put in operation, provide periodic inspection and maintenance. The check points listed below will assist you in extending the life of your Continental valves.

Fluid Operating Temperature – Fluid temperature at the reservoir during operation should be kept between 100° F. and 130° F.

Fluid Cleanliness – Control particle contamination by changing or cleaning all filter elements periodically BEFORE they become clogged and start to by-pass.

Electrical Inspection – Periodically check to assure proper voltage, and that all electrical connections are making good contact.

After Extended Shutdowns – Some types of hydraulic fluids become tacky after long periods of non-use. Manually actuate valves several times after extended shutdowns to assure that all components move freely before powering up.



CAUTION – Before manually actuating any Directional Control Valve, be sure that any resulting machine function will not endanger persons or equipment.

VSD03M VALVE REPAIR PROCEDURES
DISASSEMBLY and REASSEMBLY
GENERAL

Disassembly and reassembly of Directional Control Valves is a delicate operation. Anyone attempting it must assume responsibility for the operation of the valve. Continental valves may be returned to the factory or to an Authorized Repair Center for repair. Contact your local Distributor or Continental Hydraulics for details.

If interchanging spool types or making other conversions, restamp the escutcheon plate to show the correct code. Include stops, spool, spring, and detent orientation. See Figure 2 to serve as a guide to correct numbering.

Disassembly in the field by other than an Authorized Repair Center technician, whether for repair or modification may void warranty.

Before disassembly, study the exploded view (Figure 3) and note the orientation and location of all parts. Note that the spring retainers are used only in the assemblies that are spring centered. Special care should be taken to avoid damage to the spool and/or body bore. Even a microscopic nick in a land on the spool or body may ruin the valve.

All valves can be disassembled and reassembled in a horizontal-mounted position, provided there is adequate space and the work area is clean.

Place the spool in a bath of clean oil to coat it with a protective film, and ease assembly. Inspect o-rings for nicks, and make sure they are well oiled. It's a good idea to replace all seals whenever the valve is disassembled.

Continental valves are precisely machined to exacting tolerances. Do not force any parts, or overtighten threaded fasteners.

PART AND ASSEMBLY IDENTIFICATION

The following chart, and Figures 3 and 4 may be used to identify individual parts and assemblies in directional control valves.

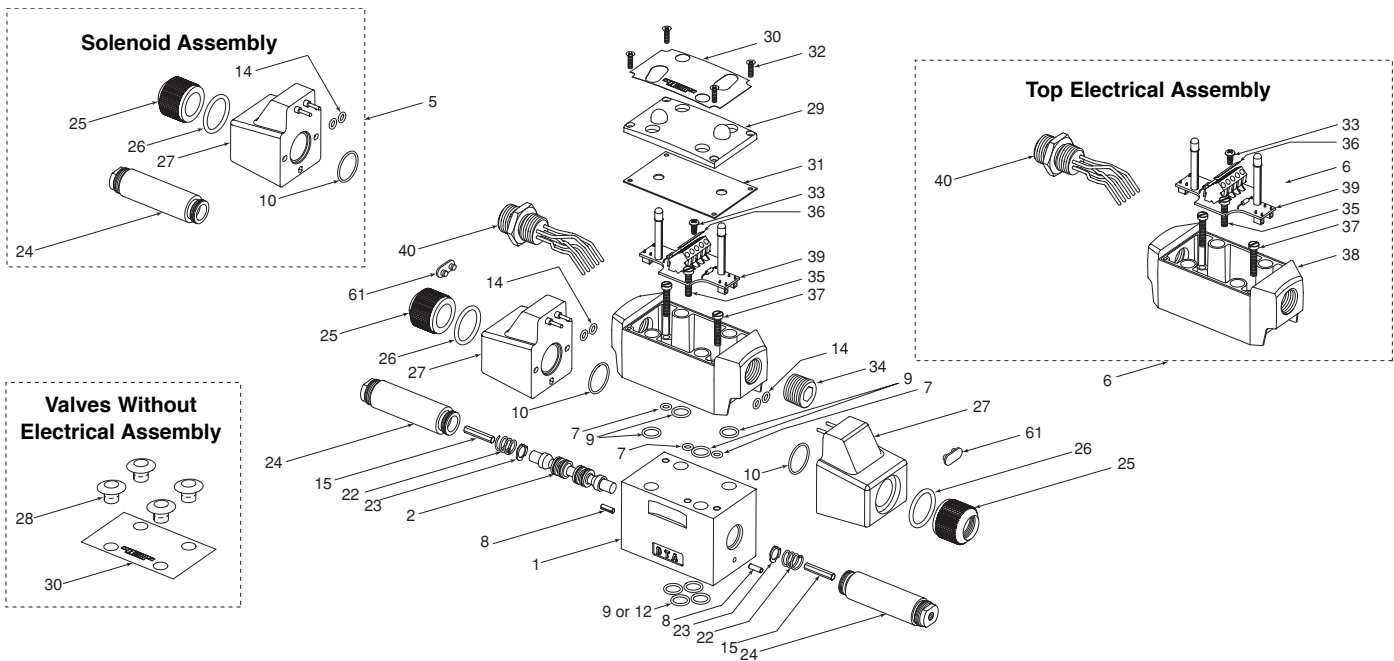

Figure 3

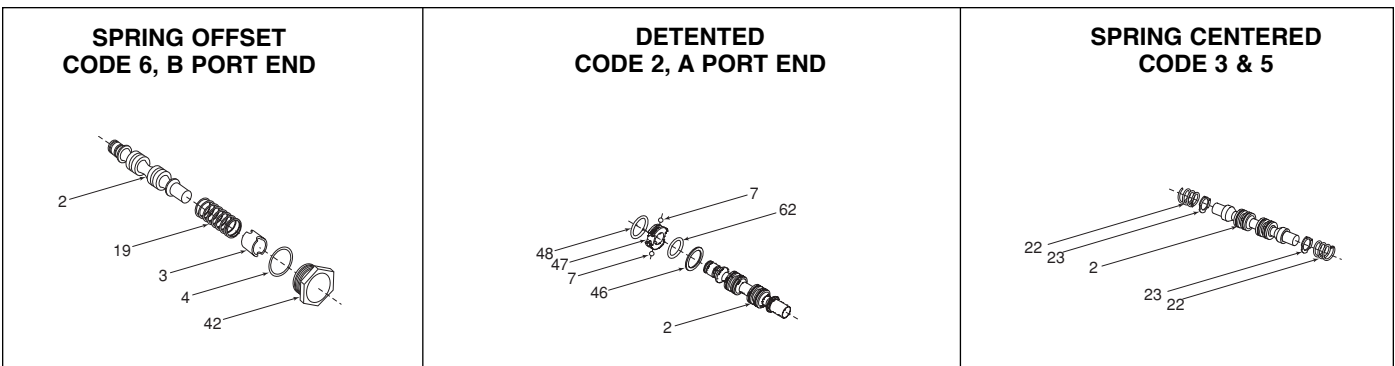

Figure 4

ITEM NO.	CODE	PART # NO.	DESCRIPTION	QUANTITY REQUIRED	ITEM NO.	CODE	PART # NO.	DESCRIPTION	QUANTITY REQUIRED
1		552411	VALVE BODY	1	22	CODE 3, 5	251786	CENTERING SPRING	2
1	M	552492	VALVE BODY	1	22	SPOOL G,L			
2	1, 2	450902	A SPOOL	as required	22	CODE 3, 5	262261	CENTERING SPRING	2
2	3, 5, 6	450835	A SPOOL	as required	22	SPOOL L 68L			
2	1, 2	450903	B SPOOL	as required	22	CODE 3, 5	252576	CENTERING SPRING	2
2	3, 5, 6	450836	B SPOOL	as required	22	SPOOL A, B, F, G 68L			
2	3, 5"	450837	E SPOOL	as required	22	CODE 3, 5	262261	CENTERING SPRING	2
2	3, 5"	450839	F SPOOL	as required	22	SPOOLS E, F, F1, J, K, N			
2	3, 5	450914	F SPOOL	as required	22	CODE 3, 5	251785	CENTERING SPRING	2
2	CODE 68, 39				22	SPOOL H, Q			
2	3, 5	450838	F1 SPOOL	as required	23	CODE 3, 5	262324	SPRING RETAINER	2
2	3, 5	450840	G SPOOL	as required	24	AC	351444AB	CORE TUBE	as required
2	3, 5	450841	H SPOOL	as required	24	DC	350037	CORE TUBE	as required
2	3, 5	450842	J SPOOL	as required	25	All	250643	SOLENOID RETAINER RING	as required
2	3, 5	450837	K SPOOL	as required	26	All	260383	O RING	as required
2	3, 5	351430	L SPOOL	as required	27	33L	147185	COIL	as required
2	3, 5	450842	N SPOOL	as required	27	34L	147186	COIL	as required
2	3, 5	450841	Q SPOOL	as required	27	42L	147188	COIL	as required
3	6A, 6A-R,	262393	SPOOL STOP	1	27	44L	147190	COIL	as required
3	6B	253203	SPOOL STOP	1	27	60L	450912AD	COIL	as required
4	1, 5, 6	121533	O-RING	1	27	68L	450912AB	COIL	as required
5	33L	262337	SOL ASSY	as required	27	61L	450912AC	COIL	as required
5	34L	262338	SOL ASSY	as required	27	70L	450911AC	COIL	as required
5	42L	262345	SOL ASSY	as required	27	75L	450911AB	COIL	as required
5	44L	262346	SOL ASSY	as required	28	WD OPTION	262765	TOP CAPS	4
5	60L	262342	SOL ASSY	as required	29	B, B5H	552464	ELEC BOX COVER	1
5	61L	262343	SOL ASSY	as required	30	2 PIN	262389	TOP LABEL	1
5	68L	262344	SOL ASSY	as required	30	DIN	262390	TOP LABEL	1
5	70L	262347	SOL ASSY	as required	31	B, B5H	351428	TOP COVER GASKET	1
5	75L	262348	SOL ASSY	as required	31	B, B5H	351455	TOP COVER GASKET	1
6	B-60L	351429AD	TOP ELEC ASSY	1		WD OPTION			
6	B-61L	351429AE	TOP ELEC ASSY	1	32	B, B5H	262349	TOP COVER SCREWS	4
6	B-68L	351429AD	TOP ELEC ASSY	1	33	B, B5H	262350	GROUND SCREW	1
6	B-70L	351429AC	TOP ELEC ASSY	1	34	B, B5H	262263	PLASTIC PIPE PLUG	1
6	B-75L	351429AB	TOP ELEC ASSY	1	35	B, B5H		CIRCUIT BOARD MOUNTING SCREWS	2
6	B5H-60L	351433AD	TOP ELEC ASSY	1	36	B, B5H	262566	TERMINAL LABEL	1
6	B5H-61L	351433AE	TOP ELEC ASSY	1	37	B, B5H	262351	ELEC BOX SCREWS	2
6	B5H-68L	351433AD	TOP ELEC ASSY	1	38	B, B5H	N/A, See 6	TERMINAL BOX	1
6	B5H-70L	351433AC	TOP ELEC ASSY	1	39	B, B5H	N/A, See 6	CIRCUIT BOARD	1
6	B5H-75L	351433AB	TOP ELEC ASSY	1	40	B5H	26294	5 PIN CONNECTOR	1
7	2 PIN	260381	O-RING	3	42	CODE 1, 5, 6	351446	ENDCAP	1
8		4223	ROLL PIN	2	42	CODE 1, 5, 6	262650	ENDCAP	1
9		108295	O-RING	DIN=4 2PIN= 8 DIN "M" = 2 2PIN "M" = 6"	44	DIN	262765	CAP PLUG KIT	1
10		259672	O-RING	as required	46	CODE 2	253429	SPACER	1
12	CODE M	109781	O-RING	DIN = 2 PIN = 6	47	CODE 2	350245	DETENT RETAINER	1
14	2 PIN	119399	O-RING	2	48	CODE 2	252445	O-RING	1
15	1, 2, 3, 5	251637	DRIVE PIN	as required	49	CODE 2	122327	BALLS	2
15	6A, 6A-R	253386	DRIVE PIN	1	60	CODE 1, 6	252647	STOP	1
15	6B	258456	DRIVE PIN	1	60	SPOOLS A & B			
16	1, 6	351431	GROMMET PLUG	1	60	CODE 2	262568	STOP	1
19	CODE 1	263008	OFFSET SPRING	1	61	CODE 1, 5, 6	351431	Plug	as required
19	CODE 1 68L	262573	OFFSET SPRING	1	62	CODE 2	109781	O-RING	1
19	CODE 6A	251785	OFFSET SPRING	1					
19	CODE 6A 68L	262573	OFFSET SPRING	1					
19	CODE 6B	251783	OFFSET SPRING	1					
22	CODE 3, 5	255519	CENTERING SPRING	2					
	SPOOL A & B								

TYPICAL ELECTRICAL and RESPONSE TIME

Solenoid Code		Voltage & Frequency	Voltage Limits Min-Max	Inrush Current Max	Holding Current (Amps)	Holding Power (Watts)
Lead Wire	DIN Conn					
60L	33L	120 V / 60 Hz	105-127	5.00	.91	45
		110 V / 50 Hz	96-115	6.20	1.10	43
68L		120 V / 60 Hz	108-132	3.70	.38	22
		110 V / 50 Hz	99-121	3.75	.42	21
61L	34L	240 V / 60 Hz	210-255	2.90	.48	45
		220 V / 50 Hz	193-233	3.00	.53	43
70L	42L	24 VDC	20-26	1.80	1.80	44
75L	44L	12 VDC	10-13	3.60	3.60	44

PERFORMANCE SPECIFICATIONS

Maximum Operating Pressure	P A B Ports	5000 psi	345 bar
	T Port	3000 psi	207 bar
Maximum Cycle Rate		400 cpm	
NFPA Mounting Surface		D03	
Weight	Single Actuator	8.75 lbs.	3.9 kg
	Double Actuator	9.75 lbs.	4.4 kg

D03 MOUNTING SURFACE

See Figure 5.

Conforms to ANSI/B93.7-M-1986 ISO 4401 Size 03.

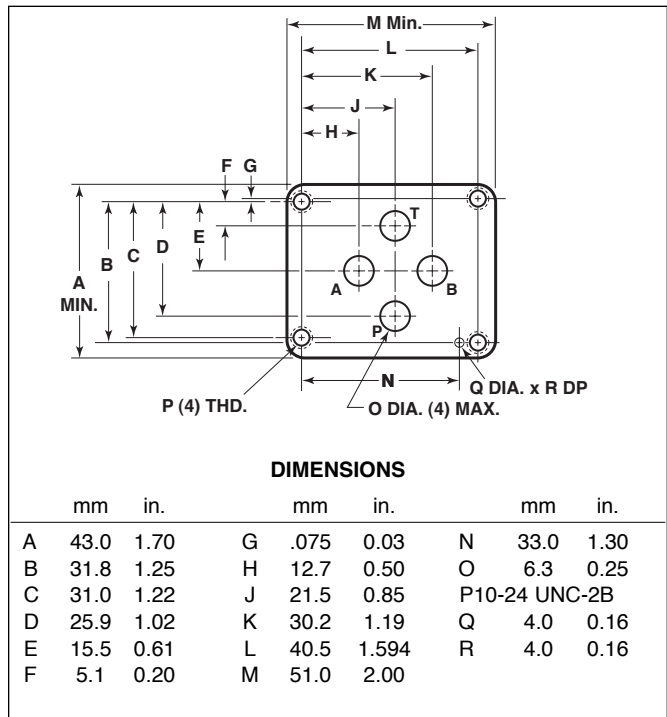

Figure 5

TROUBLESHOOTING GUIDE

PROBLEM	POSSIBLE SOLUTION
Erratic or binding valve spools	Drain and flush the system. Disassemble valve and check spool and plug assemblies for burrs or other damage. Replace parts as necessary.
New valve does not function.	Improper installation. See page 1 for valve flow path/actuating patterns. Check electric connections and circuit breakers. Confirm that hydraulic fluid type and viscosity meet specifications given on page 1.
Overhauled valve does not function.	Improper reassembly or reinstallation. See page 2 for reassembly information. See page 1 for valve flow path/actuating patterns. Confirm that hydraulic fluid type and viscosity meet specifications given on page 1.
Valve leakage	Check for leaking seals. Replace as needed.
Repeated solenoid burnout	Check voltage to determine that it is within $\pm 10\%$ of rating. See page 3. Check that opposing solenoids are not being energized simultaneously.
Detent spool does not shift properly.	Check that solenoid is energized long enough to ensure complete shift. See page 4 for typical response time.
Cylinder controlled by valve won't hold its load.	Confirm that there is no internal leakage in the cylinder, and that there are no fluid leaks in the power system. If no other sources of leakage are found, disassemble valve and check for wear or scoring on body bore and spool. Replace defective parts.



Continental Hydraulics
12520 Quentin Avenue South
Savage, MN 55378 U.S.A.

Phone: (952) 895-6400 Fax: (952) 895-6444

Because Continental Hydraulics is continually improving its products, specifications and appearance are subject to change without notice.