



Description:

This closed loop position module provides synchronized motion. It may be applied in pairs, each module driving a hydraulic cylinder for a “Master-Master” system of synchronized motion. This pair of cylinders can quickly and accurately move hydraulic cylinder loads in unison. Or, it may be applied in a “Master-Slave” mode, where up to three “Slave” axis will closely follow the “Master” axis.

Position and velocity commands are from analog sources. Cylinder feedback is from an analog source.

Stroke dependent deceleration is used to provide quick and repeatable positioning. Internal ramp and velocity adjustments allow for easy system tuning.

A wide range of analog signals are accepted. User may select either voltage or current input mode. These inputs are easily scaled to match system requirements.

Output is an analog voltage, 0 to +/- 10v, suitable for directly driving a proportional directional valve with on board electronics.

This module is easily adapted to a variety of system requirements. All variables are user adjusted with easy to use software on your Microsoft Windows laptop. Control variables are stored in non-volatile memory internal to the module. All variables can be read by the laptop, and reproduced exactly on other modules.

Technical Data:

Power Supply	Consumption	vDC	12 to 30 (including ripple)	Digital Inputs	V	Logical 0 = < 2		
	External Fuse	mA	<100mA		V	Logical 1 = > 10		
Analog Inputs	Voltage	vDC	0 to + 10	Impedance	ohm	25k		
	Impedance	ohm	33k	Analog Output	Voltage	vDC	0 to +/- 10	
	Current	mA	0 to + 20 (typ 4 to 20)		Current	mA	5 (max)	
	Impedance	ohm	250	Resolution	%	0.024		
	Resolution	%	0.01	Housing	Module		Snaps to 35mm DIN Rail EN 50022	
	Sample Time	mS	1.0		Material			Polyamide PA 6.6
	(Speed Input) Voltage	vDC	0 to +10		Combustability Class	UL94		V0
(Speed Input) Impedance	ohm	90k	Protection Class	IP	20			
Digital Outputs	V		Logical 0 = < 2 (50mA max)	Working Temperature	C	-20 to +60		
	V		Logical 1 = ~ Power Supply	Storage Temperature	C	-20 to +70		
Electrical Connection	Programming Port		RS-232 3.5mm Stereo Jack	Humidity	%	95 (non condensing)		
	Power and Signal		4 strips with 4 screw terminals each	Electro Magnetic Compatibility				
	Ground		via DIN Rail	Emission		EN 61000-6-2		
				Immunity		EN 61000-6-3		
				Vibration Resistance		EIC 60068-2-6		

Functional Diagram:

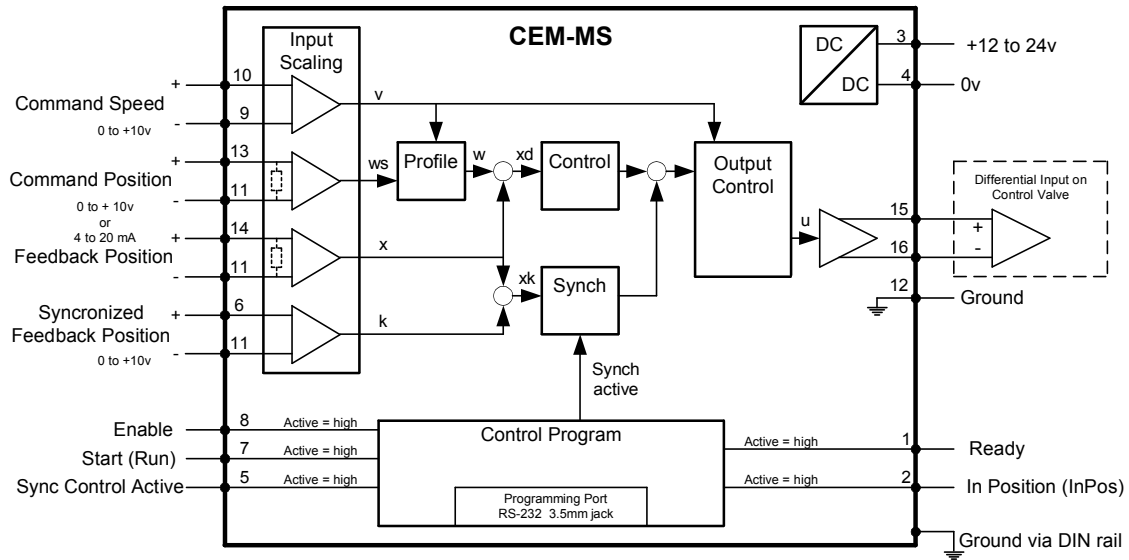

Wiring Example:

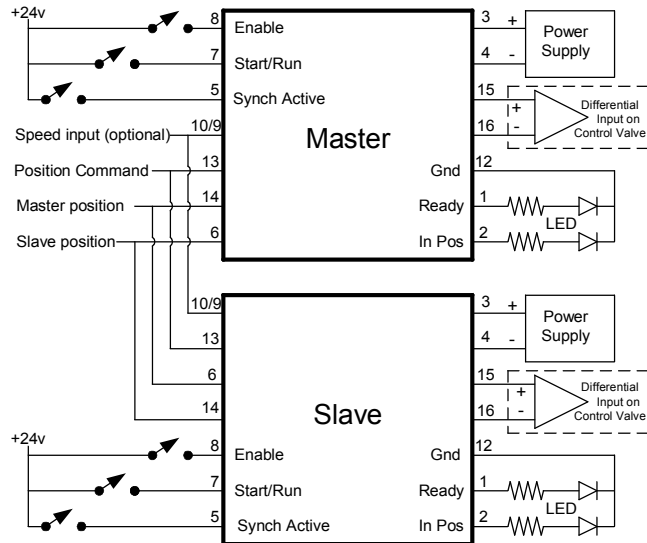

Dimensions:

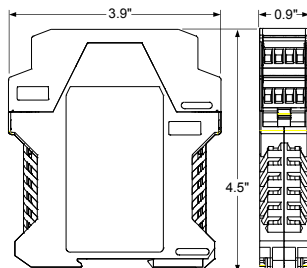

Steps to install and configure a new application:

1. Mount the module in a suitable location
2. Connect the power supply
3. Connect inputs and outputs
4. Adjust analog inputs to voltage or current, and adjust input scaling
5. Adjust analog output to match valve characteristics
6. Adjust ramping and speed parameters
7. Adjust stroke dependant deceleration parameters to tune system performance
8. Adjust internal monitor functions (if desired)

All parameters are adjusted using VEA-USB programming cable and CHI-PC Microsoft Windows application:

Module Mounting Location:

This module is to be mounted in a cabinet for protection from the local environment. Ensure there is adequate free space around the module to allow for cooling air flow. This module is designed to snap onto an industry standard 35mm DIN rail. Do not mount near other modules that emit high power electrical interference, such as motor controllers and high power contactors.

Power Supply:

This module is designed to operate on DC power from a regulated power supply ranging from 12 to 30 volts.

A 3 amp medium action fuse is recommended in the “+” power supply line.

Adjust MODE to STD or EXP:

Simple parameters may be adjusted while in STD mode.

EXP mode allows for more complex parameter adjustments.

MODE parameter valid options are STD and EXP. Default is STD.

TS parameter:

TS sets the sample time of the closed loop control system. Valid settings are from 5 to 30 Units are msec. Default is 10. It is advised to keep this parameter set to 10.

Stroke Dependent Deceleration:

The CEM-MS module uses the position control theory of stroke dependant deceleration. When a new position is commanded, the initial motion profile is ramped and speed controlled in open loop mode. As the load travels, it soon gets to a preprogrammed point, termed the braking point. At the braking point, the module converts to closed loop control, constantly adjusting the speed of the load, homing in on the final stopping point.

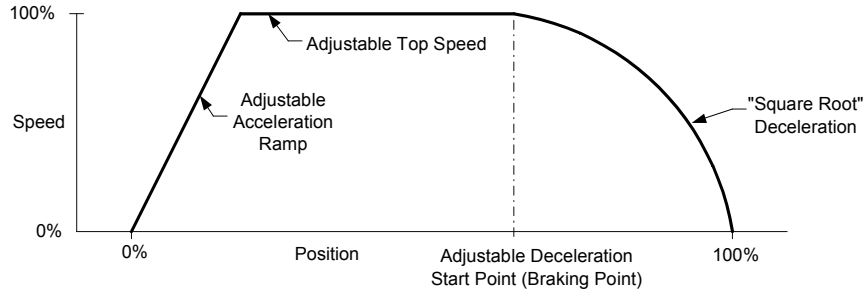

The main parameters used to control this profile include:

- STROKE: load distance.
- A:A and A:B: ramping times
- VELO: internally controlled velocity
- D:A and D:B: Deceleration start point

STROKE defines the full motion. Valid options are 10 to 10000. Default is 100. Units are mm.

A:A and A:B parameters are acceleration (ramp) rates. A:A is the direction of the load connected to the A work port of the proportional directional valve (+voltage out of CEM-MS Pin 15). A:B is acceleration of the B port. Valid options are 1 to 5000. Default is 100. Units are msec.

All ramp rates are set via software. All ramps are specified in milliseconds, and are actually “time to ramp for a 0 to 100% signal change.”

Example: A value of 2000 will give a ramp time of 2 seconds for a VELO parameter of 100% (10000). The ramp time will be 1 second for a VELO parameter of 50% (5000).

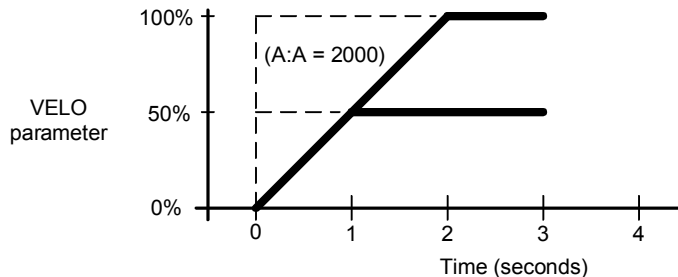

D:A and D:B are the deceleration start points(braking points). Valid options are 1 to 10000. Default is 10. Units are mm.

Stroke Dependent Deceleration (continued):

System velocity command can be either external or internal.
VS can be set to either INT or EXT. INT is default.

INT requires the speed to be set with the VELO parameter.
VELO valid values are 0 to 10000. Default is 10000(100%). Units are 0.01%

EXT uses the 0 to 10v analog voltage at pins10/9 to command speed.
This speed signal may be ramped with the VRAMP parameter.
VRAMP valid values are 1 to 5000. Default is 50. Units are msec.

Deceleration characteristic is controlled by the CTRL parameter.
CTRL valid options are LIN, SQRT1, and SQRT2. Default is SQRT1.
SQRT1 gives the best performance for most systems. SQRT1 balances quick motion control with accurate final position holding.
SQRT2 increases the gain at the final position, which may provide more precise load holding. This higher gain may introduce final position instability.
LIN gives the most stable option, but requires more time to complete the motion profile.

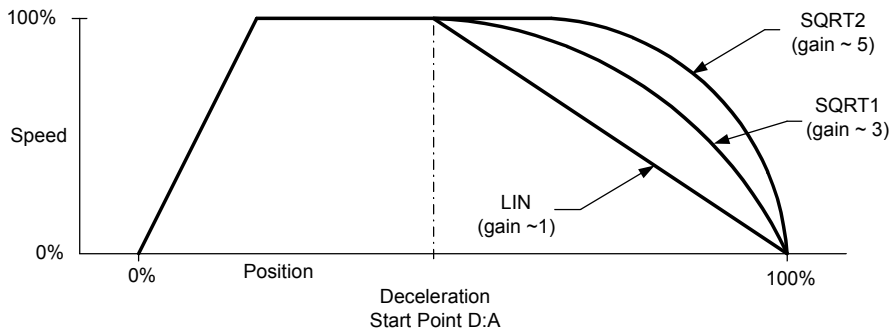

Synchronization Control:

A two axis system may be configured as either “Master – Master” or “Master – Slave”.

“Master – Master” averages the synchronization error between the two cylinders.

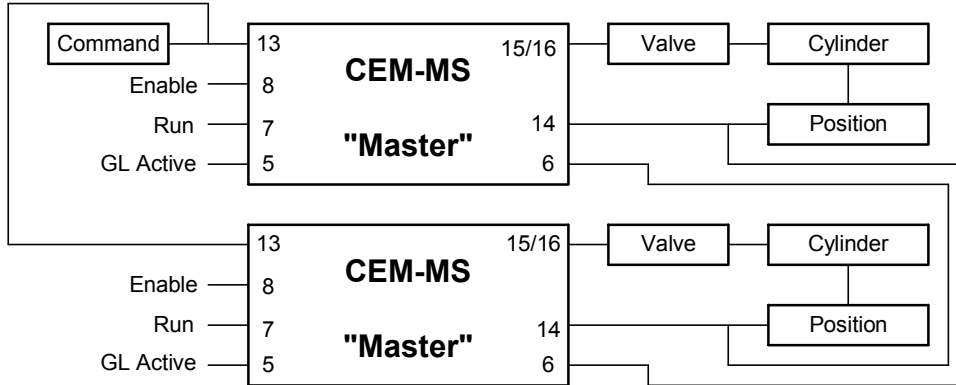

Up to four axis may be synchronized in the “Master – Slave” mode.

“Master – Slave” control theory will always have the slave “following” the master.

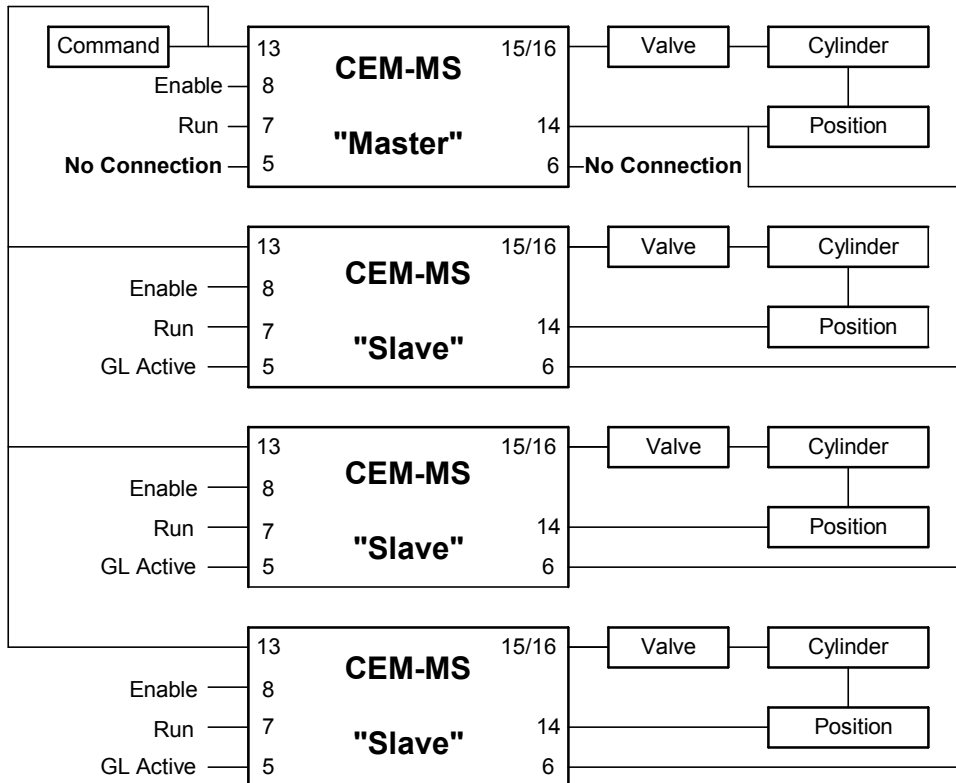

Synchronization Control (cont):

Synchronization control function diagram:

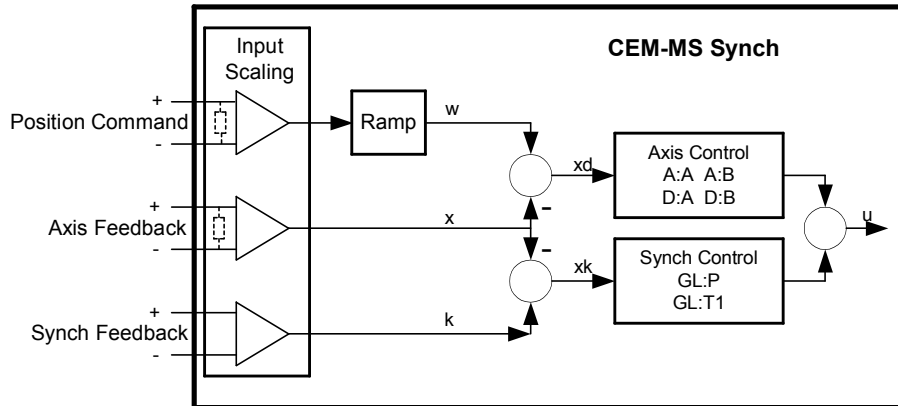

GL:P and GL:T1 parameters:

GL:P sets the synchronization gain. As with the basic single axis control, reducing the braking distance will increase the system gain, but has the potential to promote instability. Smaller values will give smaller synchronization errors. GL:P is input as a distance in mm. Valid range is 1 to 10000. Default is 2.

GL:T1 is used as a time delay to stabilize highly dynamic systems. GL:T1 has the units of milliseconds. Valid range is 1 to 200. Default is 10.

Adjust module output to match valve requirements:

The CEM-MS module has a 0 to +/-10v differential output. This output is designed to directly interface to proportional valves with on board electronics.

This output signal may be configured to more closely match the valve characteristics. The parameters used to adjust the output signal include:

- MAX:A and MAX:B
- MIN:A and MIN:B
- TRIGGER

MAX:A and MAX:B are set with software as a percentage of the native +10v output. MAX:A and MAX:B are set at 100% (10000) for a valve that has a 10v input rating. To reduce the maximum flow from a valve with a spool that is too large, set MAX to a number less than 100%. Valid range is from 5000 to 10000. Default is 10000. Units are 0.01%

MIN:A and MIN:B are adjusted via software for the purpose of deadband elimination. A valve with a minimum control point (cracking point) will give best performance if this deadband is eliminated. Valid range is 0 to 5000. Default is 0. Units are 0.01%.

Example: A directional control valve has an input range of 0 to +/-10v. The valve is factory calibrated to begin flow at 1v, and max flow is at 10v. Adjust the CEM-SA parameters:

- MAX:A = 10000 (100% of +10v)
- MIN:A = 900 (9% of 10v = +0.9v)
- MAX:B = 10000 (100% of -10v)
- MIN:B = 900 (9% of -10v = -0.9v)

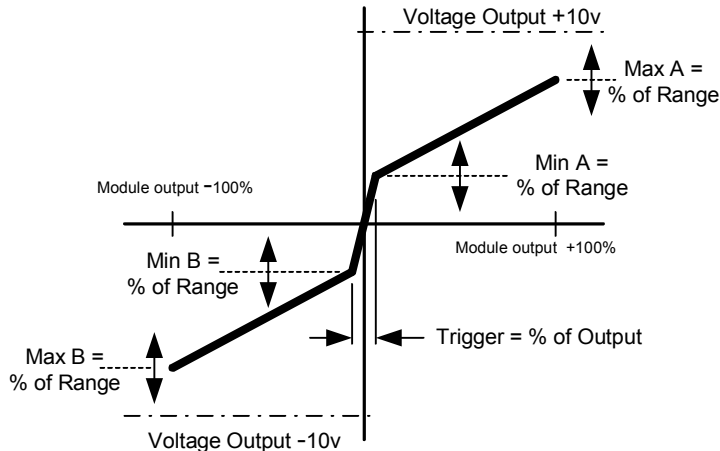

TRIGGER and MIN can be used together to optimize valve performance near zero.

When using a proportional valve with an overlap spool, adjust TRIGGER to 200 (2%), and MIN:A and MIN:B to slightly less than the “crack point” of the valve.

Adjust module output to match valve requirements (continued):

When using a proportional valve with an underlap spool (“zero” lap), the flow gain in the area of the underlap is about double that outside the underlap area. Adjusting TRIGGER and MIN:A and MIN:B as suggested will give more stable results.

Example: Adjust TRIGGER to 200 (2%) and MIN:A and MIN:B to 100 (1%). These settings reduce the flow gain in the underlap region, and usually allow for a shorter braking distance (D:A and D:B). This scheme gives quick motion, with stable load holding.

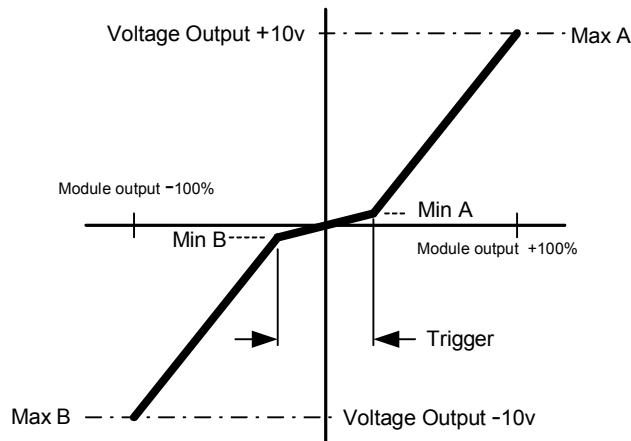

Choosing between overlap spool and underlap spool proportional valves:

There are performance tradeoffs in choosing an overlap spool valve vs. an underlap spool valve:

An overlap spool valve will do a better job of holding the load in a static condition. An overlap valve can be commanded to go to center. In this center condition, the valve port-to-port leakage is lowest. When trying to hold a load at a fixed position with the control system inactive, the overlap valve in a centered condition will allow a smaller amount of port-to-port leakage.

A negative feature of an overlap spool valve is the time delay in electronic deadband elimination. An overlap spool valve needs time to jump back and forth across the deadband during the near zero flow portion of the motion profile. This time delay will show up as slower response to external forces moving the load from the commanded position.

Adjusting the deadband elimination feature may be time consuming.

The underlap spool valve does not lose time jumping across the deadband area. The high flow gain in the underlap region provides small active position holding errors. There is an energy cost penalty in choosing the underlap spool, due to the port-to-port leakage in the center position.

Command input with Voltage:

An analog source voltage may be either “differential” or “ground referenced”. The CEM-MS accepts an analog position command and feedback inputs that are ground referenced. The optional velocity command input is a differential input. Examples are shown for position command only, feedback signals are wired to pin 14(+) and pin 11 (GND) and to pin 6 (+) and pin 11 (GND).

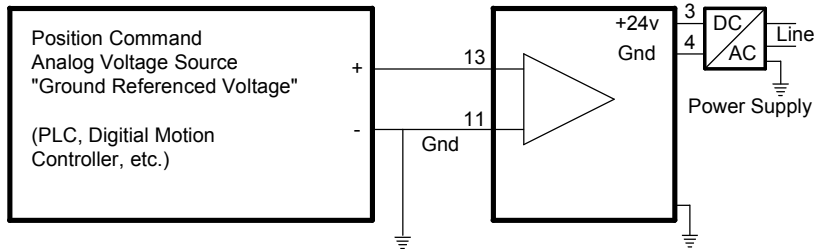

An external position command voltage source must be referenced to ground for proper operation.

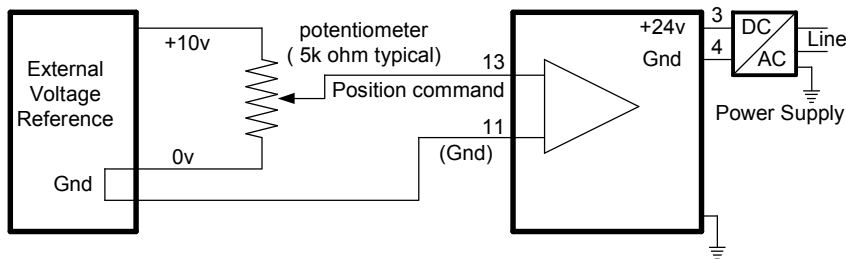

The speed command input accepts differential voltage.

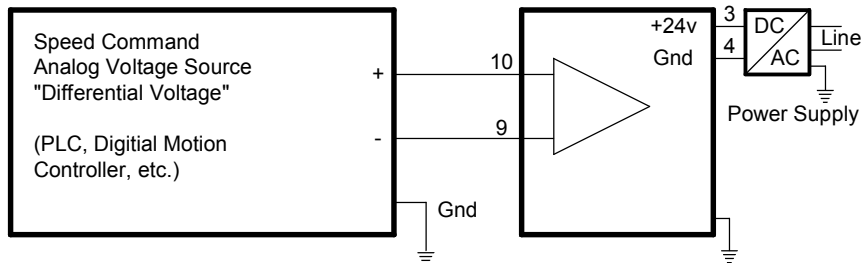

A ground referenced speed command must be referenced to the CEM-MS ground.

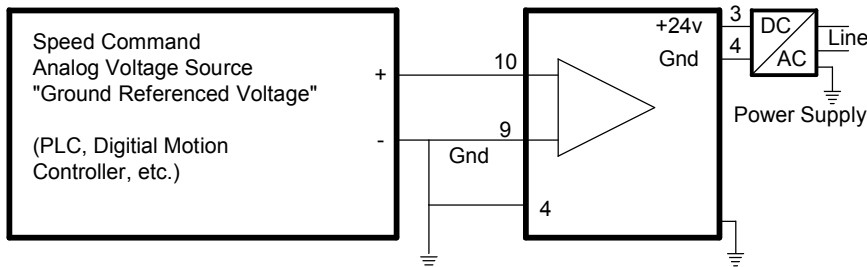

Command input with Current:

The analog position and feedback inputs may be software set to accept a current command. Either input can be individually adjusted to accept either voltage or current. When current is chosen, a 250 ohm resistor is internally inserted across terminals 13 and 11, and/or between terminals 14 and 11. This resistor converts the current to a voltage. This voltage is measured by the amplifier to become the system command (13/11) or the system feedback (14/11) and (6/11).

Input current range is 0 to +20 mA, and is typically used at 4 to 20mA. This current is converted to voltage, and software scale and offset parameters are applied to meet system requirements.

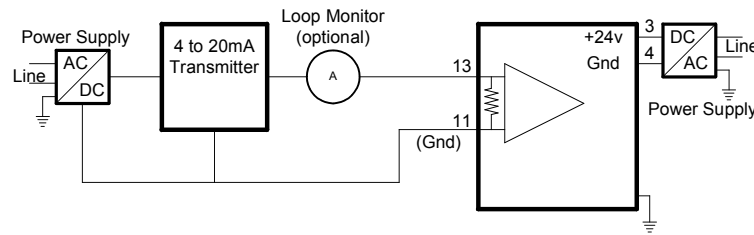

When using current as a command or feedback signal that is connected to more than one module, only one module may use a resistor to convert the current to voltage. All modules must have parameter scale and offset adjustments for current feedback.

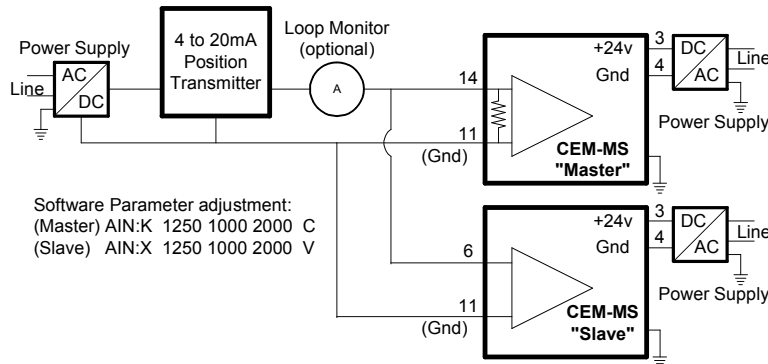

All analog input signal cables must be shielded!

Good analog system design requires that all analog signals in an electrically noisy environment be shielded. Long wires act like antennas that pick up analog noise. The wire connecting the analog command source to command this module must be shielded! An unshielded cable can allow electrical noise to be added to the desired command signal, and can make the system response erratic.

Shielding a noise sensitive wire is accomplished by wrapping a noise blocking foil or braided shield around the signal wire. This shield must be grounded at only one end, usually the end that sends the signal. A control cable may have many individual conductors. The conductors may be shielded individually, or may be shielded as a group. Short signal wires in electrically quiet environments may not need to be shielded.

The CEM family of modules all have an internal ground connection to the DIN rail. For this module ground to be effective, please insure the DIN rail is properly grounded.

Scaling of analog input:

This module has a native analog voltage input range of 0 to +10v for command and feedback. These inputs may be scaled and offset with software to allow a wide variety of input voltages. A few examples are:

0 to +10v, 0 to +5v, +1 to +5v, +0.5 to +4.5v

The AIN:W parameter adjusts command port, and AIN:X parameter adjusts the feedback port. Each can be independently set for either voltage or current command, and each can be independently scaled.

Example: AIN:W V will set the command input to voltage. Default range = 0 to +10v

Example: AIN:W C will set the command input to current. Default range = 4 to 20mA

Example: AIN:X V will set the feedback input to voltage. Default range = 0 to +10v

Example: AIN:X C will set the feedback input to current. Default range = 4 to 20mA

Analog voltages or currents are scaled with the following linear equation:

$$\text{Output} = A/B * (\text{Input} - C)$$

“Output” of this scaling equation must always be equal to the module native input range, 0 to +10v. “Input” can be any voltage within this 10v range.

The ratio of A/B allows for a decimal scaling factor. These two numbers are chosen to provide a “gain” to the input signal. A and B must be whole numbers. Range is -10000 to 10000. (Default; A = 1000, B = 1000)

C is an offset, measured as a percentage of range. C has units of 0.01%, and has the range of -10000 to 10000. (Default; C = 0)

Scaling of voltage inputs:

Example: Typical AIN parameter settings for popular command and feedback voltages:

Command	A	B	C	description
0 to +10v	1000	1000	0	100% scale, 0% offset
0 to +10v	1	1	0	100% scale, 0% offset
0 to +10v	10	10	0	100% scale, 0% offset
0 to +5v	10	5	0	200% scale, 0% offset
+1 to +9v	10	8	1000	125% scale, 10% offset
+0.5 to +4.5v	10	4	500	250% scale, 5% offset
0 to 8v	10	8	0	125% scale, 0% offset

Scaling of current inputs:

Example: Typical AIN parameter settings for popular command and feedback currents:

Command	A	B	C	description
4 to 20mA	20	16	2000	125% scale, 20% offset
4 to 20mA	1250	1000	2000	125% scale, 20% offset
4 to 20mA	5	4	2000	125% scale, 20% offset
0 to 20mA	20	20	0	100% scale, 0% offset

Swapping polarity with the POL parameter:

The output drive polarity may be swapped with the POL command.
Valid parameter values are "+" and "-". (Default = +).

Adjustment of SENS internal monitoring function:

This module has optional input and internal monitoring functions. The module can monitor command inputs for proper range.

There are three choices for SENS; OFF, ON, and AUTO (default).

OFF disables the internal sensing function.

ON and AUTO enable the internal sensing functions. The difference between ON and AUTO is how the module handles error correction.

When ON is selected, if the module detects an error, the module will disable.
After the error is corrected, the ENABLE pin must be cycled to reactivate the module.
When AUTO is selected, if the module detects an error, the module will disable.
When the error is corrected, the module will resume function without cycling ENABLE.

If the module has been configured to accept current commands, a command value outside of 4 to 20 mA will disable the module, and cause the green READY LED to blink.

EOUT parameter:

EOUT sets a default module output value. When ENABLE (pin 8) has been removed, or the module has become disabled, the output may be set to a value other than zero. This allows the machine to slowly extend or retract in the case of loss of electro hydraulic control.

Parameter valid -10,000 thru +10,000. Default is 0. Units of 0.01%

OFFSET parameter:

OFFSET is a fixed adjust to the output. OFFSET valid values are from -4000 to +4000. Units are 0.01%. Default is 0.

ENABLE (pin 8) digital input:

ENABLE is a digital input that is active high.
When the ENABLE input is low, there is no output to the valve. Command input and feedback input values are ignored. All other inputs are also ignored.

If ENABLE is removed during an active motion profile, the output to the valve is instantly brought to zero.

START (RUN) (pin 7) digital input:

START (RUN) is a digital input that is active high.

Bringing pin 7 high (while holding pin 8(ENABLE) high), forces the module into closed loop position control mode.

If RUN is removed during an active motion profile, the output to the valve is ramped to zero during the preset emergency stop distance parameter (D:S). Units of D:S are mm. Default is 10.

GL Active (Synchronization Active) (pin 5) digital input:

GL (Synch active) is a digital input that is active high.

Bringing pin 5 high (while holding pin 8(ENABLE) and pin 7 (Run) high), forces the module into closed loop position control synchronization slave mode.

With GL Active low (off), the module will operate as a single axis closed loop position control module (functionally equivalent to a CEM-SA)

InPOS pin 2 digital output:

InPOS (pin 2) is a digital output that is normally low. When the module is in active control, this output will be high, as long as the controller is within INPOS parameter. INPOS parameter is valid from 2 to 10000. Units are micrometer. Default is 1000.

When the control module is active, but outside of the INPOS parameter, the InPOS output will go low. The module continues to actively control the valve.

READY pin 1 digital output:

The READY digital output reports the system status.

Pin 5 will be held "high" (on) when ENABLE is connected, and there are no system errors.

Pin 5 will be pulled "low" (off) under the following conditions:

1. When ENABLE is removed
2. When SENS is turned on and the input is outside the 4 to 20mA range
3. When other internal errors are present

LED function:

Green (Ready)	Steady on	System OK
	Blinking	4 to 20mA current input command is out of range
Yellow (Status)	Blinking	internal error sensed
	Steady on	Synch error is within InPOS tolerance
	Off	Synch error is outside InPOS tolerance

Parameter monitoring using software:

The following parameters may be monitored in real time using Windows configuration software.

Parameter	Description	Unit
WA	Command	mm
W	Command after scale & ramp	mm
X	Feedback after scaling	mm
K	Synch control input	mm
XD	Command – Feedback	mm
XK	Synch error (X-K)	mm
V	Velocity command	0.01%
U	Output	0.01%