



# SERVICE MANUAL

## VSD08M Solenoid Actuated, Pilot Operated Directional Control Valves

“A” Design Series

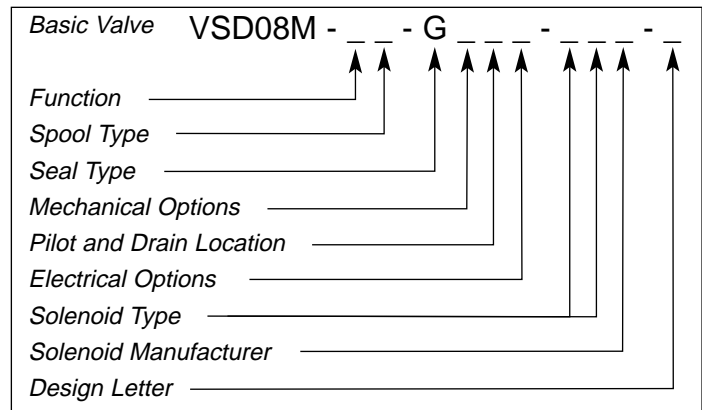

Figure 2



**CAUTION** – Before performing any service operation on any Directional Control Valve, be sure that all pressure has been relieved from BOTH SIDES of the system.



**CAUTION** – Before performing any service operation on any Directional Control Valve, disconnect or lock off power supply.



**CAUTION** – Before manually actuating any Directional Control Valve, be sure that any resulting machine function will not endanger persons or equipment.

### PRODUCT IDENTIFICATION

Each Directional Control Valve has an Ordering Code printed on its cover label. See Figure 1 for the location of the Ordering Code.

This Service Booklet applies to products with Ordering Codes like the sample in Figure 2.

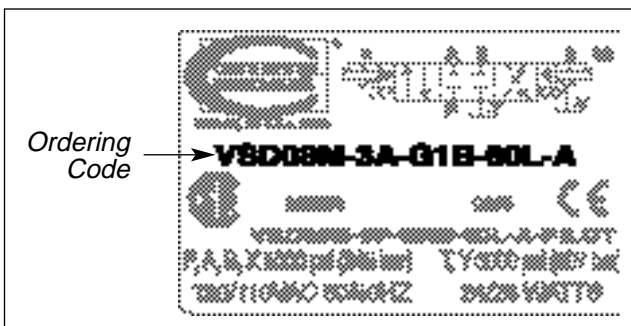

Figure 1

### GENERAL SPECIFICATIONS

#### RECOMMENDED FLUID

Petroleum, water-based fluids (not more than 40% water) and most phosphate esters. Other fluids may be acceptable, but special O-rings may be required. Viton seals are standard.

#### FLUID TEMPERATURE RANGE

Fluid temperature up to 200° F. (93° C.) will not appreciably affect valve performance. However, for safety reasons, temperatures above 130° F. (54° C.) are not recommended.

#### RECOMMENDED OPERATING VISCOSITY

80 to 350 SUS (16 to 75 CS).

#### FILTRATION

ISO 18/16/13 or better.

#### MOUNTING POSITION

Any unrestricted position acceptable. Horizontal mounting preferred.

#### NFPA FLOW PATH/ACTUATING PATTERN

SOLENOID, AIR AND OIL ACTUATED:

Actuating operator a – connects flow to cylinder port A.

Actuating operator b – connects flow to cylinder port B.

#### GENERAL INFORMATION

SOLENOID ACTUATED – Spring centered and spring offset valve types will be spring positioned unless actuated continuously. Detented, no-spring valves may be actuated momentarily. When solenoid is not actuated, the spool will remain in last position attained, provided there is no severe shock, vibration or pressure surge.

Pressure surges in a common tank line serving these and other valves can be great enough to cause inadvertent valve shifting. This is particularly critical in the no-spring, detented type valves. Separate tank lines may be necessary.

**NOTE:** Any sliding spool valve held shifted under pressure for long periods may stick and not spring return due to fluid residue formation. To prevent sticking, valves should be cycled periodically.

#### PREVENTIVE MAINTENANCE

After Directional Control Valves have been put in operation, provide periodic inspection and maintenance. The check points listed below will assist you in extending the life of your Continental valves.

**Fluid Operating Temperature** – Fluid temperature at the reservoir during operation should be kept between 100° F. and 130° F. (37° C. and 54° C.).

**Fluid Cleanliness** – Control particle contamination by changing or cleaning all filter elements periodically BEFORE they become clogged and start to by-pass.

**Electrical Inspection** – Periodically check to assure proper voltage, and that all electrical connections are making good contact.

**After Extended Shutdowns** – Some types of hydraulic fluids become tacky after long periods of non-use. Manually actuate valves several times after extended shutdowns to assure that all components move freely before powering up.



**CAUTION** – Before manually actuating any Directional Control Valve, be sure that any resulting machine function will not endanger persons or equipment.

**VSD08M VALVE REPAIR PROCEDURES  
DISASSEMBLY and REASSEMBLY  
GENERAL**

Disassembly and reassembly of Directional Control Valves is a delicate operation. Anyone attempting it must assume responsibility for the operation of the valve. Continental valves may be returned to the factory or to an Authorized Repair Center for repair. Contact your local Distributor or Continental Hydraulics for details.

If interchanging spool types or making other conversions, remark the escutcheon plate to show the correct code. Include stops, spool, spring, and detent orientation. See Figure 2 to serve as a guide to correct numbering.

Disassembly in the field by other than an Authorized Repair Center technician, whether for repair or modification may void warranty.

Before disassembly, study the exploded view on Page 3 and note the orientation and location of all

parts. Special care should be taken to avoid damage to the spool and/or body bore. Even a microscopic nick in a land on the spool or body may ruin the valve.

All valves can be disassembled and reassembled in a horizontal-mounted position, provided there is adequate space and the work area is clean.

Place the spool in a bath of clean oil to coat it with a protective film, and ease assembly. Inspect o-rings for nicks, and make sure they are well oiled. It's a good idea to replace all seals whenever the valve is disassembled.

Continental valves are precisely machined to exacting tolerances. Do not force any parts, or overtighten threaded fasteners.

**PART AND ASSEMBLY IDENTIFICATION**

The parts drawing and parts list on Page 3 may be used to identify individual parts and assemblies in directional control valves.

**VSD08M PILOT AND DRAIN**

Continental pilot operated valves are ordered from the factory with either internal or external drains. Converting the pilot or drain to either internal or external mode may be done as follows:

When internal pilot and/or drain is used, the corresponding "X" and "Y" ports in the subplate must be plugged. The pilot pressure, whether internal or external, must be at least 70 psi (5 bar) greater than the pressure at the tank ("T") line. It may be desirable to use external pilot when system pressure is subject to wide fluctuations. External drain must be used when either an "open" center or "tandem" center spool is used. External drain is also recommended when using pilot chokes. Pilot chokes do cause some pressure variations in the tank line that will affect spool movement if internal drain is used.

**PERFORMANCE SPECIFICATIONS**

MAXIMUM OPERATING PRESSURES	A, B, P Ports	5000 psi	345 bar
	T, & Y Ports	3000 psi	207 bar
MINIMUM OIL PILOT PRESSURE		70 psi	4.8 bar
MAXIMUM CYCLE RATE		up to 300 cpm	
NFPA MOUNTING SURFACE		ANSI/B93.7-1986 - D08 ISO 4401 - SIZE 08	
WEIGHT	Single Actuator	33 lbs.	15 kg
	Double Actuator	34 lbs.	15.4 kg

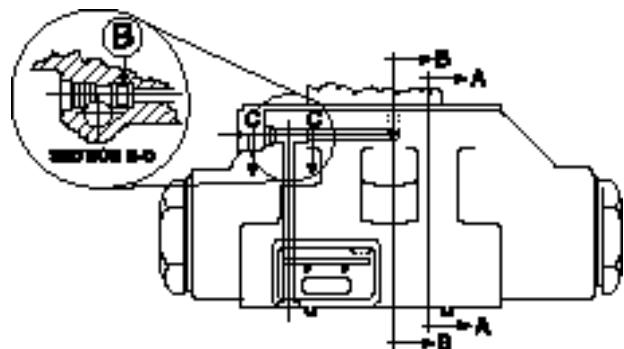

CODE	LOCATION	PILOT		DRAIN
		A	B	C
1	INTERNAL PILOT EXTERNAL DRAIN	R	B	B
2	EXTERNAL PILOT EXTERNAL DRAIN	B	R	B
3	INTERNAL PILOT INTERNAL DRAIN	R	B	O
4	EXTERNAL PILOT INTERNAL DRAIN	B	R	O

B = Blocked 1/16 NPT Pipe Plug (Item #30)  
R = Restricted 1/16 NPT Pipe Plug with 0.070 Orifice (Item #33)  
O = Open No Plug

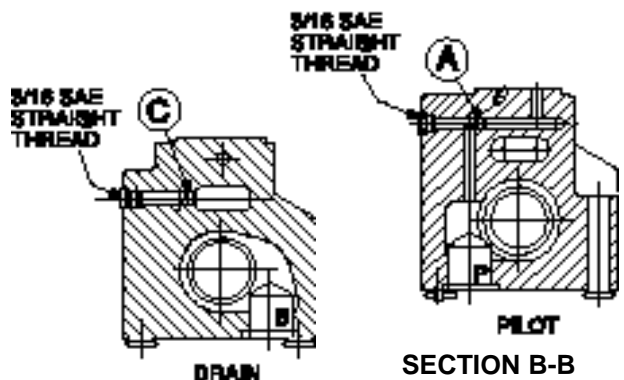

**SECTION A-A**

**SECTION B-B**

## VSD08M PARTS LIST

ITEM NO.	CODE	PART # NO.	DESCRIPTION	QTY REQ'D					
1	1		VSD08M-1A-GR-XX-XX	1	16	3, 5	167816	Spring Retainer	2
1	2		VSD08M-2A-GR-XX-XX	1	16	3, 5	253262	Spring Retainer	2
1	3		VSD08M-3F-GR-XX-XX	1	w/A*C,F*C Spools				
1	5		VSD08M-5F-GR-XX-XX	1	17	1 Only	167817	Spring Retainer	1
5	70C	166069	O-Ring	1	18	3, 5	254762	Washer	2
6	70C	350055	Check Valve Sub-Ass'y.	1	w/L Spool Only				
7	70C	350012	Poppet Seat	1	21		254389	O-Ring Boss Plug	5
8		198225	Cap Screw #10-24 x 1	4	22		164677	O-Ring	2
8	KK	199658	Cap Screw #10-24 x 2-1/2	4	23	1 Only	260109	Spring Retainer	1
9		12144	Lockwasher	4	w/A*C, F*C Spools				
11		552404	Valve Body	1	24		109413	O-Ring	2
12		409882	A Spool	1	25		109414	O-Ring	4
12		409883	A2 Spool	1	26		4269	Roll Pin	2
12		450053	A3 Spool	1	30		11794	Pipe Plug	A.R.
12		552044	AC Spool	1	33		140047	Pipe Plug w/Orifice	A.R.
12		552047	A1C Spool	1	35		108295	O-Ring	4
12		552048	A2C Spool	1	36	B**	552464	Elec. Box Cover	1
12		552043	A40C Spool	1	37*	Din Coil	262390	Label	1
12		409884	B Spool	1	37*	B**	264280M	Label	1
12		450295	B2 Spool	1	38	B**	351428	Cover Gasket	1
12		409885	F Spool	1	38	WD	351544	Cover Gasket	1
12		409886	F1 Spool	1	39	B**	262349	Cover Screw	4
12		409887	F2 Spool	1	68*		259079	Escutcheon Blank	1
12		450136	F3 Spool	1	69		250597	Escutcheon Screw	2
12		552051	FC Spool	1	80		250141	Bolt Kit	1
12		552046	F1C Spool	1	Not Shown:				
12		552045	F2C Spool	1	34	JJ, JA, JB	262333	Stroke Adj. Ass'y. (Option)	as req'd
12	3, 5	409888	G Spool	1	40	KK	262423	F03MSV Valve	1
12		409890	K-E Spool	1	71	Code 2	261749	Spool Stop	2
12	3, 5	350757	L Spool	1	w/A1C, F1C Spools				
13		351397	End Cap	as req'd	* Specify Model Code When Ordering.				
14	1 Only	164635	Spring	1					
15	3, 5	164636	Spring	2					

## VSD08M PARTS DRAWING

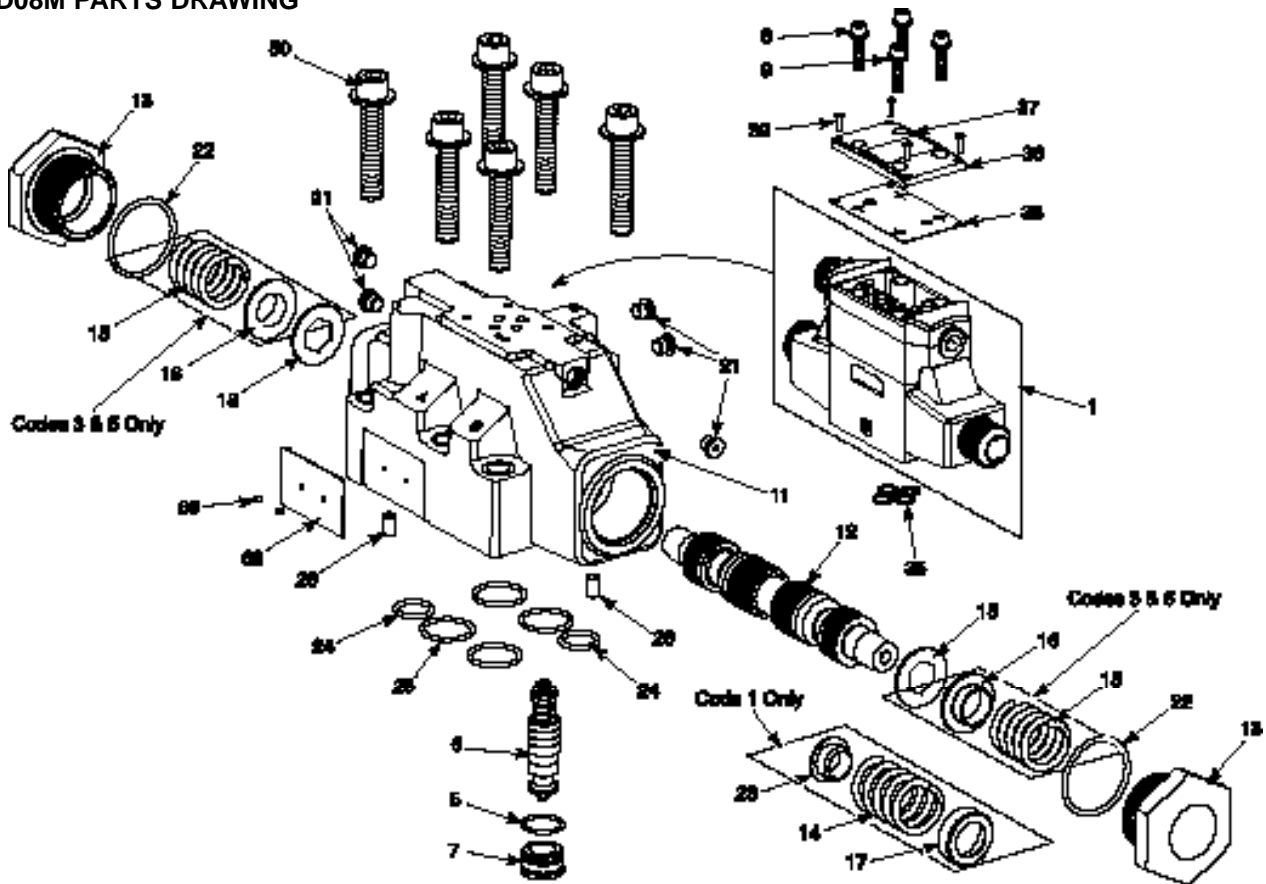

## D08 MOUNTING SURFACE DIMENSIONS

Inch	mm	Inch	mm	Inch	mm
A	6.00	154.0	J	0.44	11.1
B	5.13	130.2	K	0.69	17.5
C	4.44	112.7	L	0.19	4.8
D	3.97	100.8	M	0.69	17.5
E	3.719	94.5	N	0.75	19.0
F	3.03	77.0	O	2.87	73.0
G	2.09	53.2	P	2.93	74.6
H	1.16	29.4	Q	3.63	92.1
			R	4.57	116.0
			S	1/2-13	UNC
			T	0.44	11.2
			U	0.28	7.5
			V	0.38	9.7
			W	0.92	23.4

**NOTES:** A = Cylinder Port      T = Tank Port  
 B = Cylinder Port      X = Pilot Port  
 P = Pressure Port      Y = Drain Port

Mounting surfaces must be flat within 0.1 mm per 100 mm  
 (.0004 in. per 4.00 in.) and N8 63AA finish.

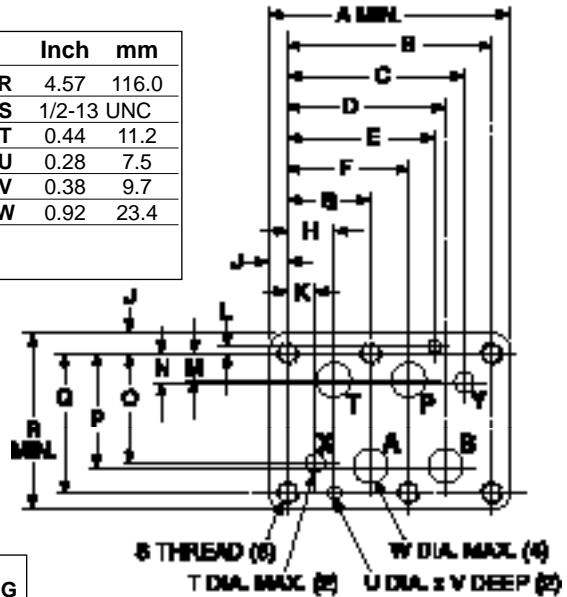

## TYPICAL ELECTRICAL AND RESPONSE TIME

SOLENOID CODE	VOLTAGE & FREQUENCY	VOLTAGE LIMITS	INRUSH CURRENT (AMPS)	HOLDING CURRENT	HOLDING POWER
LD.WIRE - DIN	VOLTS - Hz.	MIN. - MAX.	MAX.	(AMP)	(WATTS)
33L - 60L	120 - 60	108 - 126	2.10	.49	24
	110 - 50	99 - 116		.58	26
34L - 61L	240 - 60	216 - 252	1.10	.24	24
	220 - 50	198 - 231		.29	26
- 68L	120 - 60	108 - 132	1.10	.19	10
	110 - 50	99 - 121		.21	10
42L - 70L	24 DC	21 - 26	1.00	1.00	24
44L - 75L	12 DC	10 - 13	2.00	2.00	24

## TROUBLESHOOTING GUIDE

PROBLEM	POSSIBLE SOLUTION
Erratic or binding valve spools	Drain and flush the system. Disassemble valve and check spool and plug assemblies for burrs or other damage. Replace parts as necessary.
New valve does not function.	Improper installation. See page 1 for valve flow path/actuating patterns. Check electric connections and circuit breakers. Confirm that hydraulic fluid type and viscosity meet specifications given on page 1.
Overhauled valve does not function.	Improper reassembly or reinstallation. See page 2 for reassembly information. See page 1 for valve flow path/actuating patterns. Confirm that hydraulic fluid type and viscosity meet specifications given on page 1.
Valve leakage	Check for leaking seals. Replace as needed.
Repeated solenoid burnout	Check voltage to determine that it is within $\pm 10\%$ of rating. See chart above. Check that opposing solenoids are not being energized simultaneously.
Detent spool does not shift properly.	Check that solenoid is energized long enough to ensure complete shift. See above for typical response time.
Cylinder controlled by valve won't hold its load.	Confirm that there is no internal leakage in the cylinder, and that there are no fluid leaks in the power system. If no other sources of leakage are found, disassemble valve and check for wear or scoring on body bore and spool. Replace defective parts.



Continental Hydraulics  
 12520 Quentin Avenue South  
 Savage, MN 55378 U.S.A.

Phone: (952) 895-6400 Fax: (952) 895-6444

Because Continental Hydraulics is continually improving its products, specifications and appearance are subject to change without notice.