



REPAIR PARTS KITS

PVX Series Vane Pumps
PVX-20/29/36/46/60/75

“A” Design Series

When ordering, please include the pump model number and design letter series.

REBUILD KITS

MODEL	SAE	SAE - “P1”
PVX-20	264296	264297
PVX-29	264296	264297
PVX-36	264300	264301
PVX-46	264304	264305
PVX-60	264304	264305
PVX-75	264308	264309

Rebuild kits consists of:

REF	DESCRIPTION	QTY
1	Key	1
2	Rotor Shaft	1
3	Vane Kit	1
4	Port Plate, Cover	1
5	Roll Pin	4
6	Thrust Block	1
7	Bearing	2
8	Spacer Ring	1
9	Pressure Ring	1
10	Port Plate, Body	1
	Viton Seal Kit	1

SEAL KITS

MODEL	SAE
PVX-20/29/36	264277
PVX-46/60/75	264278

Seal repair kits consists of:

REF	DESC. PVX-20/29/36 (PVX-46/60/75)	QTY
13	O-Ring ASA-031 (ASA-035)	2
14	O-Ring ASA-162 (ASA-265)	1
15	O-Ring ASA-130 (ASA-229)	1
16	O-Ring ASA-146 (ASA-146)	1
17	Shaft Seal	1
18	O-Ring ASA-229 (ASA-237)	1
19	O-Ring ASA-110 (ASA-110)	1
20	O-Ring ASA-111 (ASA-111)	3
21	O-Ring ASA-143 (ASA-143)	1
22	O-Ring ASA-155 (ASA-158)	2
22	O-Ring ASA-157 (ASA-160)	2
23	Back-Up Ring	2
24	O-Ring ASA-139 (ASA-152)	2
*	O-Ring ASA-109 (ASA-109)	1
*	Back-Up Washer	1
*	O-Ring ASA-237 (ASA-237)	1

* Not Shown. **NOTE:** All O-Rings have durometer rating of ≥ 75 .

VANE KITS

MODEL	SAE
PVX-20/29/36	264272
PVX-46/60	264273
PVX-75	264274

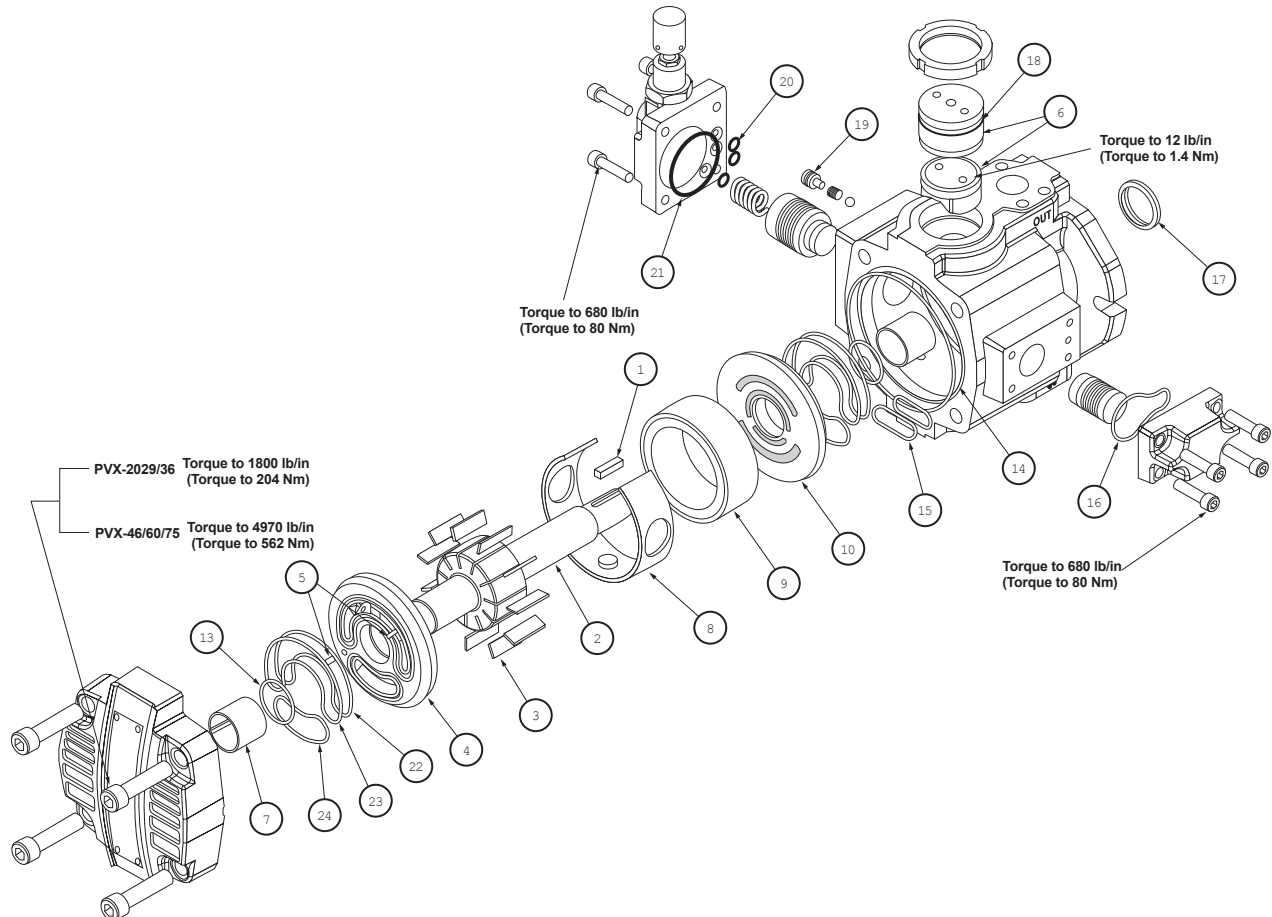

TWO STAGE COMPENSATOR

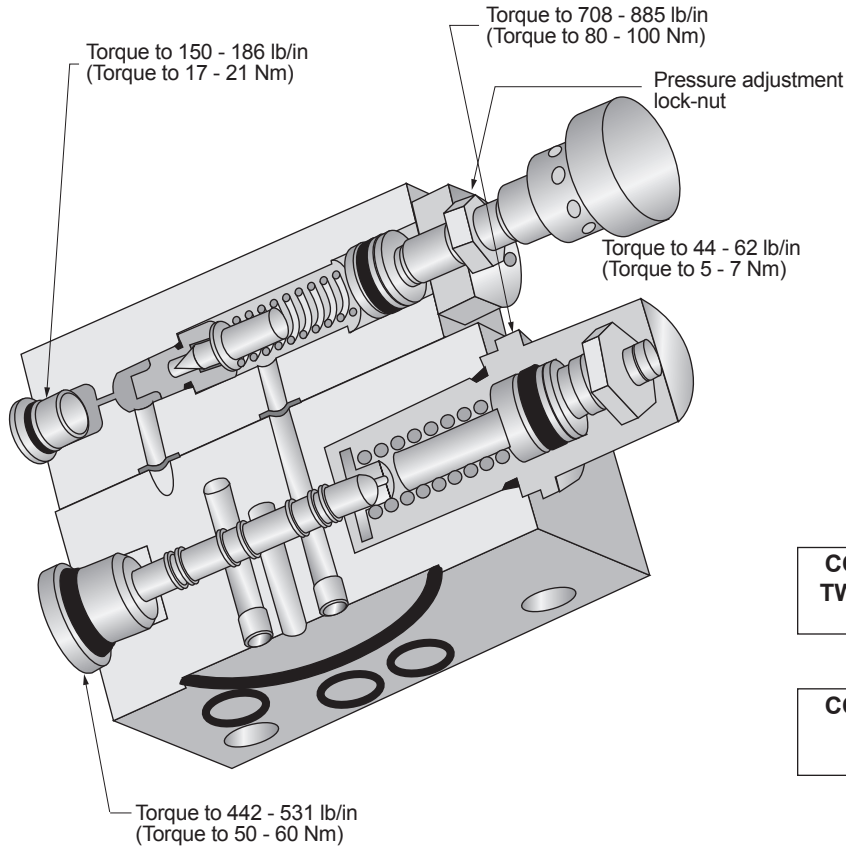

COMPLETE ASSEMBLY FOR TWO STAGE COMPENSATOR	
SAE	264407

COMPLETE ASSEMBLY FOR LOAD SENSE	
SAE	264408

NOTE: Quantity of 3, M6 socket head cap screw, not shown.
Mounts 2nd stage to 1st stage compensator.
Torque to 133 - 177 lb/in (15 - 20 Nm)



Continental Hydraulics
5505 West 123rd Street
Savage, MN 55378
Phone: (952) 895-6400 Fax: (952) 895-6444
www.continentalhydraulics.com

Because Continental Hydraulics is continually improving its' products, specifications and appearance are subject to change without notice.