

# SERVICE MANUAL

## PVX Series Vane Pumps

### “A” Design Series

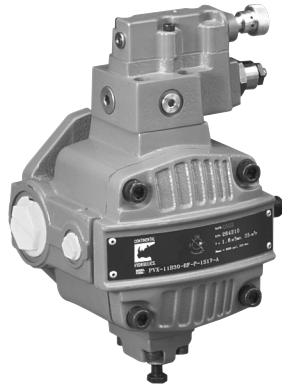

**CAUTION** – Before performing any service operation on any PVX Vane Pump, be sure that all pressure has been relieved from BOTH SIDES of the system.



**CAUTION** – Before performing any service operation on any PVX Vane Pump, disconnect or lock off power supply.



**CAUTION** – Before manually actuating any PVX Vane Pump, be sure that any resulting machine function will not endanger persons or equipment.

### PRODUCT IDENTIFICATION

Each PVX Vane Pump has a Model Code stamped on its nameplate. See Figure 1 for the location of the Model Code.

This Service Booklet applies to products with Ordering Codes like the sample in Figure 2.

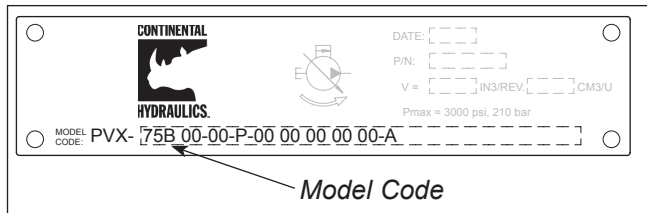

Figure 1

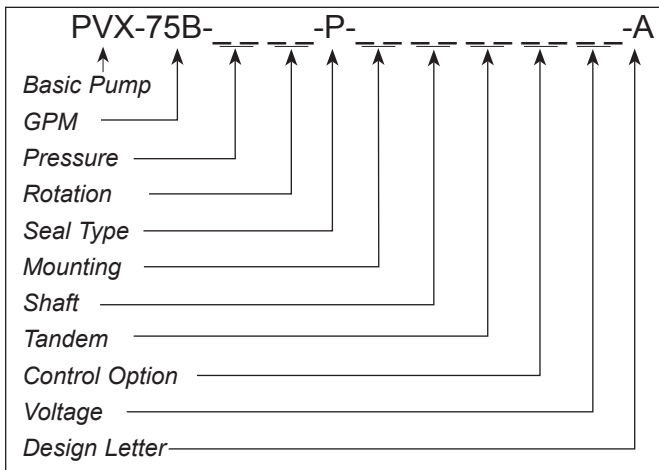

Figure 2

### SYSTEM REQUIREMENTS

**FLUID RECOMMENDATIONS** - Use premium quality hydraulic fluids which fall within the viscosity ranges listed below, at normal operating temperature. Fluids containing anti-wear additives are not required, but recommended and when used may extend the life of system components.

### FLUID VISCOSITY

Pump Model	Optimum Operating Viscosity
PVX-8	150 to 250 SUS (32 to 54 cSt)
PVX-11/15	150 to 250 SUS (32 to 54 cSt)
PVX-20/29/36	200 to 300 SUS (43 to 65 cSt)
PVX-46/60/75	200 to 300 SUS (43 to 65 cSt)

**FLUID TEMPERATURE** - Pump reservoir (bulk) fluid temperature should not exceed 130° F. (54° C.). Always select fluid for optimum viscosity at operating temperature. In no instance should fluid temperature exceed 160° F. (71° C.).

**FILTRATION** - For increased component life, fluid contamination should not exceed 16/13 per ISO/DIS 4406 “Solid Particulate Contamination Code”.

**CRITICAL SHAFT ALIGNMENT** - PROPER SHAFT ALIGNMENT IS NECESSARY TO MINIMIZE EQUIPMENT NOISE, VIBRATION AND SHAFT SEAL WEAR. Align to less than .006 inches (0.152 mm), as shown in Figures 3 and 4.

Two precision dial indicators must be used to insure proper alignment in vertical, horizontal, and parallel planes.

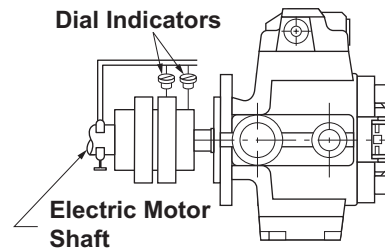

Figure 3

Coupling halves can be either engaged or disengaged. If disengaged, the outside diameter of the pump coupling must be smooth and machined true in respect to the coupling bore.

Proper alignment is achieved when neither indicator varies more than 0.006 inch (0.152 mm) during one complete shaft revolution.

## CRITICAL SHAFT ALIGNMENT (Continued...)

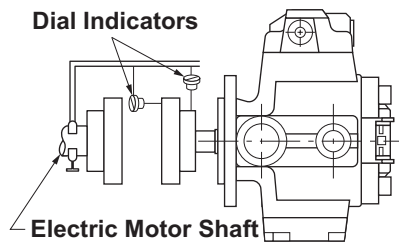

Figure 4

One indicator rides on the inside face of the pump coupling. Measuring parallel offset alignment, as in Figure 4, Proper alignment is achieved when neither indicator varies more than 0.006 inch (0.152 MM) during one complete shaft revolution.



**CAUTION - THE COUPLING SELECTED SHOULD PROVIDE A CLEARANCE FIT ON THE PUMP AND MOTOR SHAFTS.**

Never use couplings with interference or sweat fits. Do not press jaw coupling hub together tightly. Allow air gap between hub and insert to prevent end thrust into pump rotor, which will damage the pump. No external forces (other than rotational) should be applied to the shaft.

### INSTALLATION

Careful attention to the following installation requirements will assure satisfactory operation of your PVX hydraulic pump. The pump should only be installed by qualified personnel. Please read this bulletin carefully for detailed steps to install this equipment

1. REMOVE ALL PLASTIC PROTECTIVE CAP PLUGS FROM COMPONENT BEFORE INSTALLATION.
2. Prior to installation, pour a small amount of clean hydraulic circuit fluid into the pump inlet port and rotate the pump shaft by hand in the direction indicated by the arrow cast into the pump body (all PVX pumps rotate from thrust block to compensator). This insures lubrication at initial start-up.
3. Mount the pump and drive motor to a rigid base not more than three feet above the fluid level.
4. Align the pump shaft to within 0.006 inches (0.152 mm) Full Indicator Movement (F.I.M.) of the motor shaft, as in one of the two procedures outlined on the cover page of this bulletin.
5. Carefully connect the inlet, outlet and case drain plumbing to the pump. Do not force hard piping to align with the pump ports. This may pull the pump out of alignment with the motor.

The inlet line must be plumbed full size to within three inches of the bottom of the reservoir.

**PVX Models:** Case flow on all PVX pumps exits through the port located on the pump body. PVX 8/11/15 models also have an external shock clipper drain port located on the compensator that, if used, must be plumbed. PVX 20 through PVX 75 models have internal shock clipper drains and no additional plumbing is necessary.

When installing the case drain plumbing, do not install the flared portion of any fitting into the case drain port. Using flared fittings in this manner will block case drain flow causing shaft seal failure.

The case drain line must also be plumbed to within three inches of the bottom of the reservoir. The case drain and main system return lines must be separated from the pump inlet line by a baffle. The baffle causes all return flow to travel the length of the reservoir before re-entering the pump. allowing for heat dissipation and de-aeration.

6. Fill the reservoir with fluid

### INITIAL START-UP

1. Rotate the shaft by hand, in the direction of the cast in arrow, to insure freedom of rotation.
2. To prime the pump on initial start-up, it is imperative to clear all air from the pumping chambers first. To do this, open center valving should be immediately down-stream of the pump outlet port, which allows all flow (fluid and air) to pass directly to tank upon start-up. If open center valving is not included in your circuitry, position your valving to move cylinders and/or motors in a no-load condition (75 to 150 psi, 5.2 to 10.3 bar) until the pump has primed. This "no load" condition is not a pump compensating pressure value, but is strictly the result of system resistance.

Another way to clear air from the pumping chambers and prime the pump is to incorporate an automatic air bleed valve in the pump outlet port, or as close to the outlet port as possible. This valve will automatically open to allow air to exit to tank upon start-up. Once all air contained in the pump has been purged, the valve will automatically close.

3. All PVX Pumps incorporate a volume control. Continental recommends not reducing the pump's output flow by more than 50 percent on start-up (pump flow is reduced by turning the adjustment screw clockwise). Once the pump is running, the volume can be adjusted down to as low as 20 percent of maximum volume at maximum RPM.
4. Jog the motor (no more than 10 revolutions if possible) and observe the direction of rotation. If the pump shaft is not rotating in the direction as the cast arrow on the pump body indicates, reverse direction of rotation of the motor.

If rotation is correct, continue jogging the motor until the pump has primed. You will notice a definite pump tone change and pressure gauge movement when the pump begins to prime. Pressure adjustments can be made after priming the pump.

5. Pressure adjustments must be made against a blocked or dead-headed system (cylinders and/or motors stalled or valving shut off). Increase pressure by turning the pressure adjustment knob clockwise. Decrease pressure by turning the pressure adjustment knob counter-clockwise. Pump pressure setting should be as low as possible, yet high enough to insure satisfactory machine performance.

*INITIAL START-UP (Continued...)*

- Continental recommends installation of a low resistance check valve to prevent pump reversal on system shutdown.

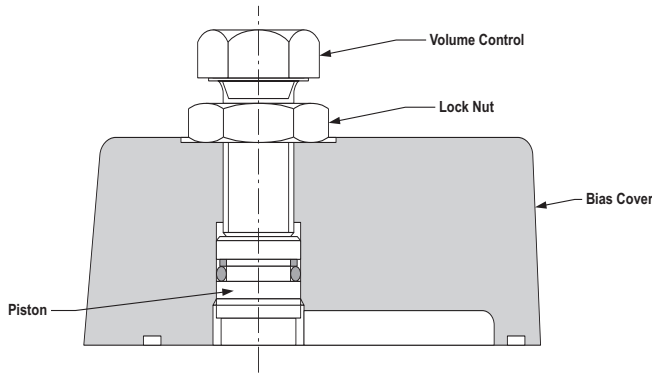

**Figure 5**

Pump Model	Nominal Stroke		Decrease in Flow Per Turn	Minimum Flow Attainable
	In.	mm		
PVX-8	0.075	1.9 mm	53%	<0%
PVX-11	0.080	2.0 mm	50%	0%
PVX-15	0.099	2.5 mm	40%	20%
PVX-20	0.077	1.9 mm	80%	<0%
PVX-29	0.106	2.7 mm	56%	8%
PVX-36	0.132	3.4 mm	44%	26%
PVX-46	0.117	3.0 mm	50%	17%
PVX-60	0.150	3.8 mm	40%	34%
PVX-75	0.186	4.7 mm	32%	47%

**VOLUME CONTROL ADJUSTMENT**

During initial start-up, volume should be at least 50% of maximum flow.

Only make adjustments to volume control with pump running at full flow and low pressure while observing output flow.

**PUMP AND SYSTEM SETTINGS**

Once the pump is primed and operating properly, pressure adjustments can be made by placing the pump in deadhead (blocked circuit, no pump flow) and turning the adjustment knob on the compensator. Each pump is factory set to a maximum pressure of approximately 500 psi (35 bar) for shipment purposes. Turning the adjustment knob in a clockwise direction will increase maximum pump pressure (compensator setting). Once the desired compensator setting is reached, tighten the lock nut on the stem to lock the adjustment in place.

- The pump compensator setting should be adjusted as low as possible, but high enough to meet all system demands. Keeping the maximum pressure as low as possible extends the pump life, reduces the amount of thermal energy generated in the hydraulic system, and decreases motor energy consumption.
- The maximum pressure setting of the pump (compensator setting) needs to be a minimum of 100 psi (7 bar) or greater above the maximum peak full flow operating pressure in the system. If this pressure differential is not great enough, pressure spikes in the system can cause the pump to become unstable or lose output flow.
- The pressure differential between the maximum pump pressure and an inline relief valve should also be set to a minimum of 100 psi (7 bar) or more. Adjusting the relief valve setting too close to the pump compensator setting can cause the pump to become unstable.
- Your PVX pump is equipped with a volume control. Adjust the output flow to the desired value. Adjustments of the volume control should only be done while the pump is running at full flow and low pressure. Clockwise rotation of the volume control adjustment will cause the pump flow to decrease. Once the desired flow is reached, tighten the lock nut on the volume control adjustment stem to lock the adjustment in place.

**REPAIR PARTS**

When ordering repair parts, please include pump number and design series. This information will be found on the pump nameplate as shown in Figure 1 on page 1.

# PUMP

REFERENCE	DESCRIPTION	QTY
1	Key	1
2	Rotor shaft	1
3	Vane kit	1
4	Port plate, cover side	1
5	Roll pin	4
6	Thrust block	1
7	Bearing	2
8	Spacer ring	1
9	Pressure ring	1
10	Port plate, body side	1
13	O-ring, ASA-031 / (ASA-035)	2
14	O-ring, ASA-162 / (ASA-265)	1
15	O-ring, ASA-130 / (ASA-229)	1
16	O-ring, ASA-146 / (ASA-146)	1
17	Shaft seal	1
18	O-ring, ASA-332 / (ASA-340)	1
19	O-ring, ASA-110 / (ASA-110)	1
20	O-ring, ASA-111 / (ASA-111)	3
21	O-ring, ASA-143 / (ASA-143)	1
22	O-ring, ASA-157 / (ASA-160)	2
23	Back up ring	2
24	O-ring, ASA-139 / (ASA-152)	2
24	O-ring, ASA-237 / (ASA-237)	1

PUMP REBUILD KITS		
Model	SAE Type	SAE "P1" Type
PVX-8	264288	264289
PVX-11/15	264292	264293
PVX-20/29	264296	264297
PVX-36	264300	264301
PVX-46/60	264304	264305
PVX-75	264308	264309

PUMP SEAL KITS	
SIZE	PART NUMBER
PVX-8	264275
PVX-11/15	264276
PVX-20/29/36	264277
PVX-46/60/75	264278

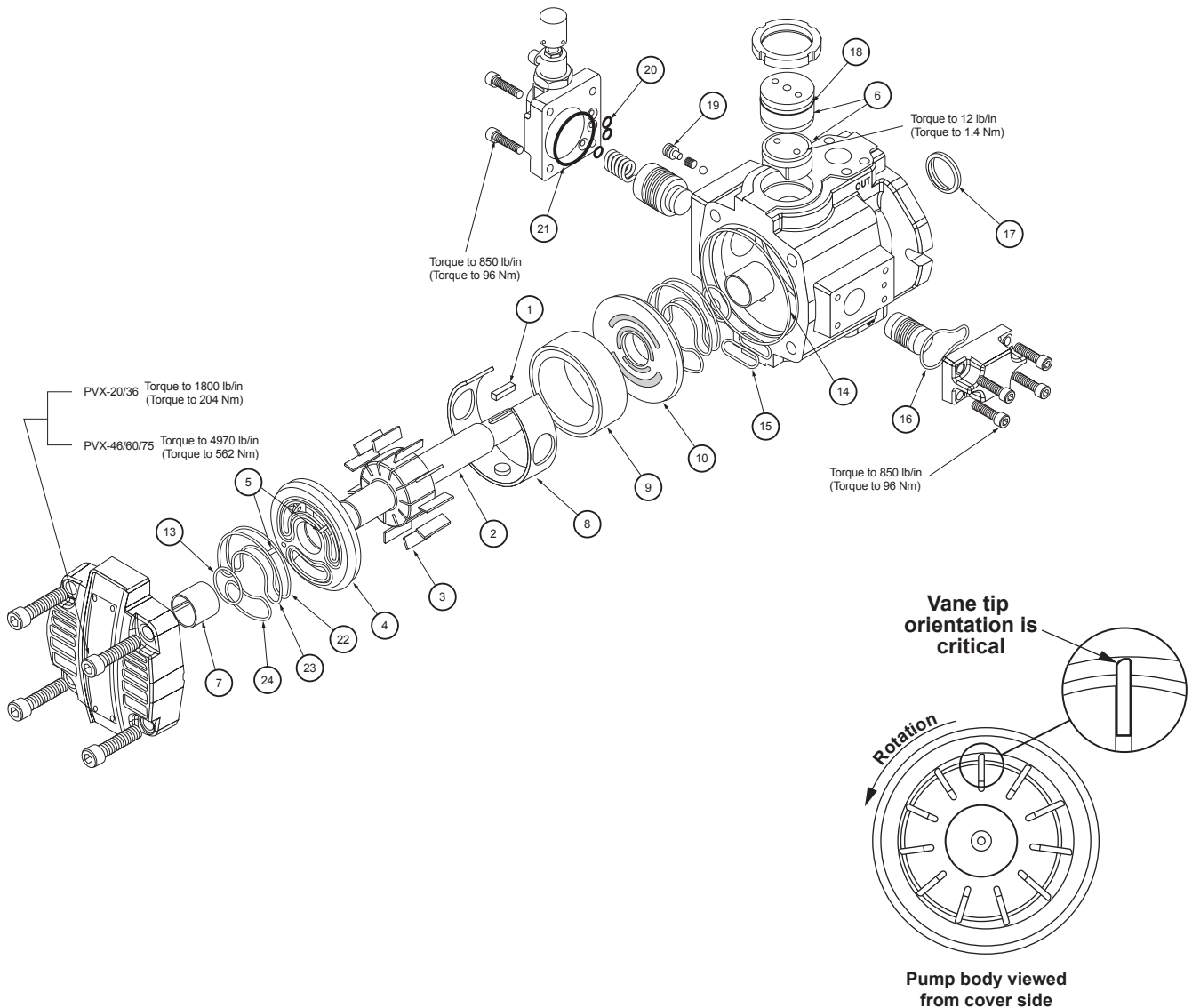

**PUMP REBUILD KITS INCLUDE:**

REFERENCE	DESCRIPTION	QTY
1	Key	1
2	Rotor Shaft	1
3	Vane Kit	1
4	Port Plate, cover side	1
5	Roll Pin	4
6	Thrust Block	1
7	Bearing	2
8	Spacer Ring	1
9	Pressure Ring	1
10	Port Plate, body side	1
-	Viton Seal Kit	1

**VITON SEAL KITS INCLUDE:**

REFERENCE	DESC., PVX-20/36/(PVX-46/75)	QTY
13	O-ring, ASA-031 (ASA-035)	2
14	O-ring, ASA-162 (ASA-265)	1
15	O-ring, ASA-130 (ASA-229)	1
16	O-ring, ASA-146 (ASA-146)	1
17	Shaft Seal	1
18	O-ring, ASA-332 (ASA-340)	1
19	O-ring, ASA-110 (ASA-110)	1
20	O-ring, ASA-111 (ASA-111)	3
21	O-ring, ASA-143 (ASA-143)	1
23	Back Up Ring, Port Plate	2
24	O-ring, ASA-139 (ASA-152)	2
	O-ring, ASA-155 (ASA-158)	2
	O-ring, ASA-113 (ASA-113)	1
	Back Up Ring	1
	O-ring, ASA-109 (ASA-109)	1
	Back Up Washer	1

(All o-rings durometer rating ≥ 75)

**TROUBLESHOOTING YOUR PVX PUMP**

Problem	Possible Cause	Corrective Action
<b>Excessive Noise</b>	1) Coupling misalignment	Align the pump and motor shaft to within .006 of an inch total indicator reading. The tighter the alignment, the quieter the pump will be.
	2) The continuous pressure is significantly above or below rated specifications for 210 bar pumps.	The pumps have been sound tuned at rated pressure. Consult factory for proper pressure setting.
	3) Fluid in the reservoir is low and the pump is sucking air.	Fill the reservoir so that the fluid level is well above the end of the suction line during all of the working cycle.
	4) Restricted inlet.	If a suction strainer is used, check it for obstructions or dirt. We do not recommend the use of strainers. They tend to be a leading cause of cavitation which manifests as excessive noise. Check also for shop rags left in the reservoir.
	5) Air leak in the suction line.	Tighten all fittings. If it still leaks, smear grease over the joints to locate the leak.
	6) Suction line has too many elbows, or is too long.	The suction line should be as short and as straight as possible to reduce resistance to flow.
	7) Air in the fluid.	The return line should terminate below the fluid level to prevent splashing.
	8) Suction line is too small.	Suction line should always be equal in size to the suction port. <b>Never</b> reduce it.
	9) Vane does not move freely.	Contamination in the fluid, or a burr in the vane slot can cause a vane to bind up. Proper filtration and/or deburring of the vane slots is required.
	10) Vane is installed incorrectly.	The leading edge of the vanes must be oriented in the direction of rotation. The leading edge is identified as the low side of the vane taper.
	11) A vane is missing.	Make sure all vane slots have a vane in them.
	12) Port plates not properly installed.	Plates must be installed so that the arrows point in the same direction as the rotational arrows on the pump body.
	13) Pump rotating backwards.	Pump must rotate in direction indicated by arrow on pump case.
	14) Low oil level.	Fill reservoir so that oil level is well above the end of the suction line during the <b>entire</b> work cycle.

<b>Problem</b>	<b>Possible Cause</b>	<b>Corrective Action</b>
<b>Excessive Noise</b> (Continued)	15) Wrong type of oil.  16) Reservoir not vented.  17) Case drain does not terminate below oil level. 18) Worn Pressure Ring.  19) Two pumps to a common manifold.	See page 1 for oil specifications.  Reservoir should be vented through a breather cap to allow breathing action as fluid level changes.  Extend case drain piping so that it terminates below the lowest oil level during machine cycles.  Replace. This condition is caused by lack of oil, or by oil that is overheated, contaminated, or too thin for the application.  A check valve must be installed in the discharge lines of both pumps, to prevent back flow and surging. Check valves are also required when accumulators are used in the discharge lines.
<b>Pump will not prime</b>	1) Shaft rotating in the wrong direction.  2) Air leak in the suction line. 3) Pump is air bound.  4) Fluid level in the reservoir is too low. 5) Volume Control is turned in too far. 6) Suction port dust plug left in place.	When installing a pump, always jog the electric motor to check for proper shaft rotation. Rotation should only be clockwise (right hand) for PVX pumps.  Make sure all fittings are tight.  Use an air bleed valve to void the pump and suction line of air.  Fill the reservoir so that the fluid level is well above the end of the suction line.  Flow should not be reduced more than 50% of maximum. Turn clockwise to restrict flow.  Remove plug.
<b>Pump is unstable</b>	1) Contamination in the compensator. 2) Pressure ring is not moving properly.	Thoroughly clean the control orifices and check filtration.  Control piston should be checked for freedom of movement.
<b>System is too hot.</b>	1) Case drain line is installed too close to the pump inlet line. 2) Reservoir is undersized. Rule of thumb is a minimum reservoir displacement of 2 to 3 times pump output flow. 3) Pump is operating at higher than required pressure. 4) Pump is discharging through relief valve.  5) Excessive system leakage through cylinders or valves. 6) High ambient or radiant heat.  7) Low oil level in reservoir.  8) Excessive friction. 9) Restricted or undersized valves or hydraulic lines.	The case drain and pump inlet should be separated by a baffle in the reservoir.  Increase reservoir size, or add a hydraulic fluid cooler.  Reduce pump pressure to the minimum required for the installation.  Remove the relief valve. Relief valves are not required with PVX pumps having a spring or hydraulic pressure compensator governor. Relief valves create additional heat energy.  Check progressively through the system for sources of leakage.  Relocate power unit, or insulate against radiant heat.  Bring oil up to recommended level. Monitor system for oil loss.  Make sure fluid is of proper viscosity.  Clean valves and piping. Check for pinched lines. Use adequate pipe sizes.

<b>Problem</b>	<b>Possible Cause</b>	<b>Corrective Action</b>
<b>Leakage at oil seal.</b>	<ol style="list-style-type: none"> <li>1) Abrasives on pump shaft.</li> <li>2) Scratched or damaged oil seal.</li> <li>3) Coupling misalignment.</li> <li>4) Pressure in pump case.</li> <li>5) Oil too hot.</li> </ol>	<p>Protect shaft from abrasive dust and dirt. Replace oil seal.</p> <p>Re-align the pump and motor shafts. See page 1. Inspect case drain line for restriction. Use only full size pipe direct to reservoir. PVX-20 to PVX-75, check for possible check valve failure. See troubleshooting section "System is too hot."</p>
<b>Bearing Failure</b>	<ol style="list-style-type: none"> <li>1) Contaminated fluid.</li> <li>2) Coupling misaligned.</li> <li>3) System overheating.</li> <li>4) Electric motor shaft end play, or excessive force used to install or remove coupling.</li> <li>5) Incorrect fluid.</li> </ol>	<p>Drain and clean system. Refill with clean fluid Re-align the pump and motor shafts. See page 1. See troubleshooting section "System is too hot." End thrusts on pump shaft will damage bearings. Eliminate all end play on electric motors. Couplings must be a slip fit. Do not hammer or press fit.</p> <p>See fluid specifications on page 1.</p>
<b>Pump not delivering oil.</b>	<ol style="list-style-type: none"> <li>1) Pressure adjustment screw too loose.</li> <li>2) Incorrect pump rotation.</li> <li>3) Insufficient oil in reservoir.</li> <li>4) Air leak in suction line.</li> <li>5) Oil too thick to prime pump.</li> <li>6) Maximum volume control turned in too far.</li> <li>7) Bleed-off elsewhere in circuit.</li> <li>8) Pump not properly tuned.</li> <li>9) Pump cover too loose.</li> </ol>	<p>Tighten screw 3 to 5 turns after spring tension is felt.</p> <p>Pump must rotate in the direction indicated on case or nameplate.</p> <p>Fill reservoir so that oil level is well above the end of the suction line during the <b>entire</b> work cycle.</p> <p>Apply good pipe joint compound, compatible with hydraulic fluid. Tighten all joints.</p> <p>See oil viscosity specifications on page 1.</p> <p>Turn volume control screw counterclockwise to increase delivery.</p> <p>Check for open center valves, or other controls connected with a tank port.</p> <p>Recalibrate pump. See page 2.</p> <p>Replace seals if damaged, and tighten cover bolts.</p>
<b>Pump won't hold pressure.</b>	<ol style="list-style-type: none"> <li>1) Pump not delivering oil.</li> <li>2) Pressure adjustment screw set too low.</li> <li>3) Worn or damaged compensator.</li> <li>4) One or more vanes stuck in slots.</li> <li>5) Oil bypassing to reservoir.</li> <li>6) Thrust screw not set properly.</li> </ol>	<p>See troubleshooting section "Pump not delivering oil."</p> <p>Set adjusting screw to obtain desired operating pressure.</p> <p>Replace compensator.</p> <p>Inspect for contaminants or sticky oil.</p> <p>Inspect for open center valves, or other valves open to reservoir. Assure that relief valve settings are high enough above system operating pressure.</p> <p>Re-set thrust screw.</p>

## SYSTEM PLUMBING

1. Use a large diameter suction line with a minimum of elbows and sharp turns to prevent pump cavitation. As a guide, the size of the suction line should be as large or larger than the pump inlet connection. The suction line should be designed without strainers and should avoid screwed pipe joints or other poor fitting connections that may allow air into the fluid. Cavitation and aeration in the fluid can cause pump damage, instability, and excess noise.
2. The outlet line should be properly supported to resist loading from changes in system pressure. Vibration dampening supports should be located as close as possible to the pump outlet.
3. The case drain line should be less than 10 ft. [3 meters) long and lead directly back to the reservoir in a location that is always below the fluid level, but away from the suction line. As a guide, use a pipe/hose size for the case drain line as large as the pump case drain connection.
4. Do not use manual positive shut off valves in the case drain line. Do not use spring loaded check valves in the case drain line.
5. Restrictions in the case drain line should be avoided if possible. However, certain swing style (low mass) check valves and heat exchangers sized for low pressure drops may be installed in the case drain line of PVX pumps.
6. **Shaft seal failures or reduced shaft seal life will occur if the maximum case pressure of 10 psig (0.7 bar) is exceeded.**
7. **Do not connect case drain lines of multiple pumps into one common line or header.** This can lead to excessive pump case pressures and/or pressure spikes that could damage the shaft seal and other internal pump seals. Dynamic pressure variations in the case pressure can cause pump instability.
8. Case drain lines and main return line in the reservoir should be separated from the pump inlet line by a baffle system. This insures maximum heat dissipation and de-aeration of the fluid before re-entering the pump.
9. To minimize noise and vibration energy that could be transmitted to the hydraulic system, dampening flanges and supports should be used between the pump motor group and the rest of the hydraulic system. When possible, use flexible hoses in place of hard pipe to prevent unnecessary vibration. Hoses must eventually be replaced, so the

layout of the hydraulic system should allow for future hose replacement.

10. It is recommended that a low resistance check valve be installed in the hydraulic circuit downstream of the pump to prevent back-flow through the pump on system shutdowns. This in-line check valve can also prevent possible pump stability problems in circuits with large system capacitance (hoses, accumulators, large cylinders, etc.).

## PUMP INSTALLATION

11. Thoroughly clean and flush new hydraulic systems to remove contaminants that could damage your pump (for filtration requirements, see page 1). Verify fluid cleanliness prior to pump installation. Failure to remove contaminants will lead to premature pump wear and failure.
12. Mount the pump to a rigid base or bell housing, so it is no more than 3 ft. (1 meter) vertically above the fluid level in the system reservoir. PVX pumps can be mounted in any orientation.
13. After the pump has been secured, remove all plastic protective cap plugs and port covers just prior to attaching the fluid lines.
14. Carefully connect the inlet, outlet, and case drain plumbing to the pump while paying special attention not to introduce any foreign material inside the pump. Do not force hard or rigid piping to align with the pump ports. This could potentially cause misalignment of the pump motor group or damage the pump internals.
15. On PVX-8/11/15 models, there is an external shock clipper that can optionally be plumbed to the tank. The shock clipper can limit the extent of dynamic pressure spikes that are imposed on the pump and circuit. It will also minimize pressure overshoot (spikes) and undershoot to improve pump stability and pressure decay times. The connection for the shock clipper is located on the side of the compensator (control) housing, and if enabled, must be individually plumbed to tank.  
**IMPORTANT:** When enabled, the shock clipper can create additional control leakage that may decrease pump efficiency. On small systems with limited cooling capability, this could result in higher fluid temperatures than desired. In these cases, pump efficiency will be maximized by not connecting the shock clipper.
16. For PVX-20 through PVX-75 models, the shock clipper is internal to the compensator design, and does not need to be externally plumbed.



Continental Hydraulics  
5505 West 123rd Street  
Savage, MN 55378  
Phone: (952) 895-6400 Fax: (952) 895-6444  
www.continentalhydraulics.com

Because Continental Hydraulics is continually improving its' products, specifications and appearance are subject to change without notice.